

Outdoor



 **SCHUCH**

**COMPETENT, INNOVATIVE
AND WITH PASSION FOR
EXCELLENT LIGHTING.**

 **SCHUCH**

TABLET OF CONTENT

130 years on the pulse of time	2
Quality, flexible, Made in Germany	4
Sustainability	
On the way to a climate-neutral company	6
BlackEdition – protecting the night sky	8
GreenLine – sustainable product design in focus	10
Technical design & functions	
Optics	14
Backside light shielding	14
Inclination angle adjustment of the LED modules	15
Zhaga-compliant LED modules	15
Painted cover plates	15
Universal pole attachment	16
Escape routes / outdoor assembly points	16
Seawater-resistant version	17
Light colours	18
Control options	
Control functions	20
EcoTune	22
VARIO concept	24
VARIO NFC	25
RFL luminaires	26
Light management LIMAS Air SYNC	30
Technical outdoor light fittings	
VIA	34
CAMINO	42
FILOS VARIO	50
LUCA	58
PENDO	70
REDONDO	
Decorative outdoor light fittings	
KONIC	76
CUPINA / PLANEO	82
CILA	88
CAPA	94
RETRO / RETRO Z	100
BELLA	106
Floodlights	
FOCO	114
FOCO L / FOCO XL	120
AREALO 2	126
AREALO 2 Sports facility lighting	132

130 YEARS ON THE PULSE OF TIME

FROM THE FIRST STREET LIGHT FOR METAL FILAMENT LAMPS TO LED LUMINAIRES AND SMART CITY SOLUTIONS.

When Adolf SCHUCH founded the company in March 1895, the invention of the light bulb was only a few years old. Fascinated by this new technology, he began producing waterproof light bulb sockets as well as porcelain and hand lamps with protective glass for use in demanding industrial environments.

As early as 1906, the first street light for metal filament lamps marked the company's entry into outdoor lighting. By 1912, the product range had grown rapidly to a considerable size and variety. Cast iron cover fittings, globe lights and wall lights with polished glass are just as much a part of the range as overhead street lights with reflectors and a variety of brackets and wall arms with ornate decorations.

With highlights such as the first mushroom-shaped post-top luminaire, the first street luminaire with a glass fibre-reinforced polyester housing and the legendary 43 and 44 series box luminaires, the development spans a period of more than 100 years right up to modern LED luminaires made of die-cast aluminium and smart city solutions with the LIMAS light management system.

A wealth of experience, innovative strength, flexibility and customer proximity are just some of our strengths that we would like to share with you. With a passion for good light, we are at your disposal as a competent partner for the realisation of your lighting projects. Put us to the test!

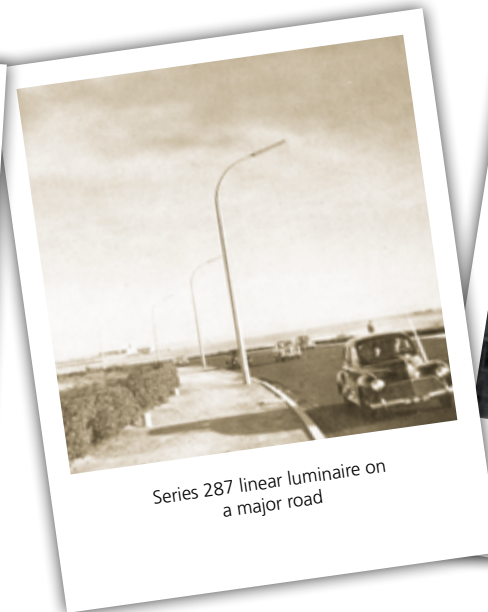

1906

Production of the first street lights for metal filament lamps.

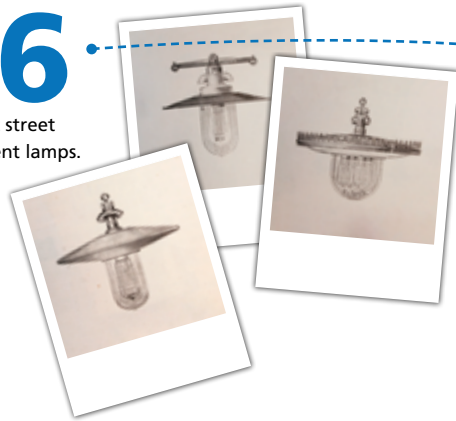

1935

Enamelled sheet steel lights with open glass, a variety of decorative lanterns, globe and bracket lights as well as the first pole-top light fitting enrich the production programme.



1949

Lights for fluorescent lamps and high-pressure mercury vapour lamps are included in the production range.

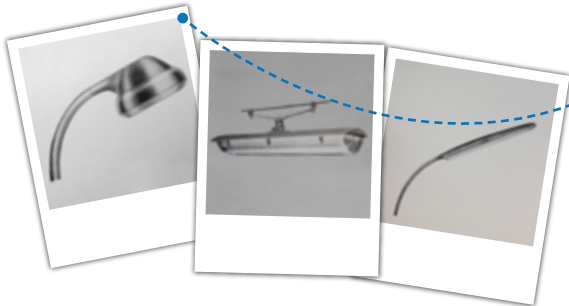

1970

Production of the first case lights made of glass fibre reinforced polyester.

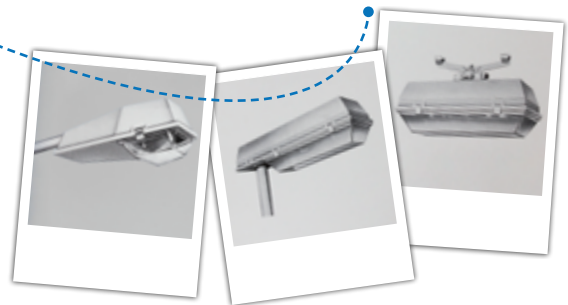

2009

The first LED street lights leave the factory in Worms. Shortly afterwards, the first luminaire series with die-cast aluminium housings, the 47 / 48 series, are launched on the market.

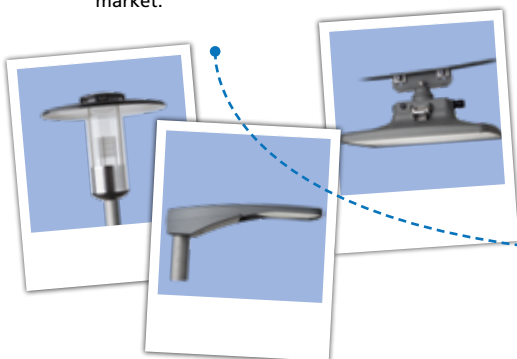

2016

Lighting becomes smart. With the introduction of the LIMAS light management system, customers have all the options for intelligent lighting control at their fingertips. From a simple stand-alone solution to an interactive network with maximum ease of use.



QUALITY, FLEXIBLE, MADE IN GERMANY

EVERYTHING FROM A SINGLE SOURCE

From design to final assembly: the company located in Worms performs all the light fitting design, testing and production stages.

SCHUCH engineers use advanced CAD systems to design new light fittings as well as special thermal simulation programs in order to reach optimal temperature control for each LED light fitting. This is a decisive factor for LED service life and, therefore, it is one of the most important quality parameters of a good LED light fitting.

Deep vertical integration in the light fitting production is typical for SCHUCH.

The forming and cutting, bending and welding of metal parts and housings are performed using modern machining centres and welding robots in mechanical manufacturing.

A modern environment-friendly powder coating unit is used to paint metal light fittings with varnish of a standard or customized colour.

Since 1953, all light fittings made of fibreglass-reinforced polyester are produced in a separate pressroom and then provided with polyurethane/silicone gaskets in a fully automated dispensing system.

The tools required for forming, bending and pressing are produced in the in-house tooling workshop.

Careful manual assembly of light fittings is performed in several assembly departments. Finally, each light fitting undergoes specific functional testing.

The moulding of explosion-proof LED boards and the ultra sonic welding of gas-tight LED lights are the latest manufacturing processes used in the Worms plant, which further extends SCHUCH's know-how. Constant quality controls and internal audits at all production levels ensure the high quality standard of all SCHUCH lights.

Continuous quality control and internal audits at all production stages ensure a high quality standard for all SCHUCH light fittings.

Light fittings, their components and materials are thoroughly tested in our own measuring laboratories, accredited by testing bodies.

Along with the lighting measurements, determination of luminous flux and representation in light distribution curves, light fittings are checked for emitted interferences and noise immunity in accordance with EMC Directive 2004/108 EC and the Electromagnetic Compatibility Act.

Dust- and water chambers are used to check IP rating of the light fittings, including sealing tests underwater.

Heat measurements to check the maximum admissible temperature, low temperature tests and material ageing tests performed in climatic chambers, especially for explosion-protected light fittings, finish the Test Programme for SCHUCH light fittings.

This comprehensive philosophy allows SCHUCH to control all processes and to react promptly and flexibly to changing requirements.





100% ORIGINAL SCHUCH

Every single light fitting of our product range is an original SCHUCH product. Designed and engineered by our own engineers, produced using own tools and 100% quality approved in our own work shop. Unique and with it distinctive.

EXCELLENT QUALITY

SCHUCH light fittings are unique branded products "Made in Germany". The proverbial high quality standard which you can rely on.

SCHUCH's quality management has been certified according to DIN EN ISO 9001 since 1995. Quality management covers all company activities from development to production and final assembly through to sales and applies to all product and manufacturing areas.

The manufacture of explosion-protected lights and components is subject to even stricter monitoring with regard to quality management in accordance with DIN EN ISO/IEC 80079-34.

This monitoring audit has been successfully carried out regularly since 1999 and confirmed with a certificate.

The highest quality standards from SCHUCH are also confirmed by the railway. Since November 7th, 2019, SCHUCH has been a certified Q1 quality supplier to the railway company Deutsche Bahn AG.



QS CERTIFICATIONS

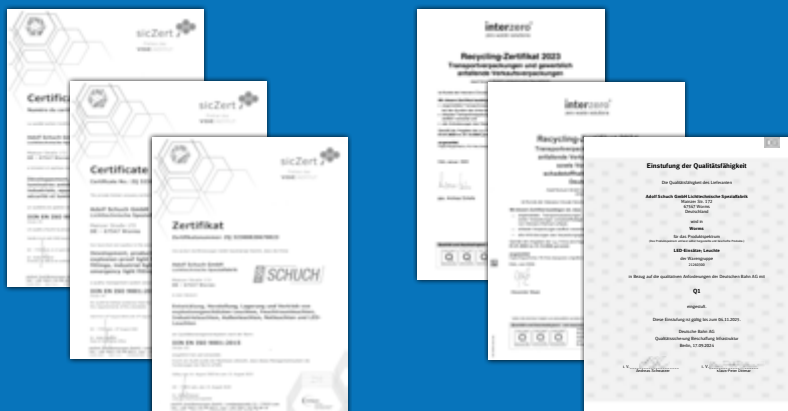

ON THE WAY TO A CLIMATE-NEUTRAL COMPANY

As a manufacturing company, we take our environmental responsibility very seriously. Oriented towards long-term goals, our actions are consistently aligned with the principle of sustainability. Through responsible use of limited natural resources and the development of sustainable products, we make an active contribution to environmental protection for a future worth living for present and future generations.

OUR LOCATION-BASED MEASURES

With permanent measures to reduce our CO₂ emissions, we have been on the way to becoming a climate-neutral company for years. The most important milestones in recent years were:

- The energetic renovation of our main building
- The conversion of our entire factory lighting to LED with corresponding lighting control concepts
- The investment in a new powder coating plant designed according to the most modern environmentally friendly aspects.
- The installation of a photovoltaic system for our own power supply on the shed roofs of our production hall.
- The start of the conversion of our company vehicles to electric cars
- The establishment of a charging infrastructure at the Worms site



The consistent focus on the development and production site in Worms also minimises transport routes. In addition, the high level of vertical integration ensures that preliminary products are often manufactured directly on site and do not have to be delivered over long distances. In addition, our plant and production processes are intensively analysed for further energy-saving potential in regular energy audits. Continuous internal process optimisation contributes to the optimal use of resources and the reduction of resource consumption.

As a responsible family business with a history of over 130 years, we are making our contribution to climate protection, reducing environmental pollution, lowering CO₂ emissions and conserving valuable resources.

NO DISPOSABLE PRODUCTS

SCHUCH light fittings are not single-use products. If necessary, all components can be replaced by specialist personnel in order to avoid unnecessary waste and to conserve valuable resources. The only exception is the gas-tight PRIMO XR series, which must be hermetically sealed due to the application.

DISPOSAL & RECYCLING

All SCHUCH products fulfil the requirements of the REACH and ROHS directives. SCHUCH is affiliated to the Interzero® / Interseroh+ recycling systems and the Grüner Punkt - Duales System Deutschland (DSD) for the professional disposal of packaging and the return and recycling of old appliances. SCHUCH thus makes a further contribution to the protection of finite resources, the climate and the environment.



REDUCE

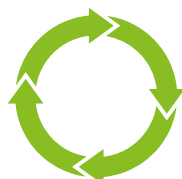

REUSE

interzero® interseroh+
zero waste solutions



Der Grüne Punkt –
Duales System Deutschland GmbH



STARRY SPLENDOUR INSTEAD OF LIGHT POLLUTION

In fewer and fewer places it is possible to experience the night sky with all its starry splendour and darkness. Light bells over cities and settlements are increasingly impairing the view of the starry sky. Artificial lighting in outdoor areas is continuously increasing the light immissions. Negative influences on people, animals and even microorganisms are increasing due to the brightness. To preserve natural darkness, outdoor lighting should only be used where necessary, only when necessary and only as bright as necessary. The solution is adaptive light with technical luminaires. Special lens optics allow precise beam characteristics. In combination with time and presence control, the luminous flux is adapted to requirements. Warm light colours such as the amber light colour (1,800K) also reduce unwanted spill light to a minimum.

Protecting the night sky from light pollution is an important task for improving the quality of life, to preserve the habitat for wildlife and protect our access to the stars. The International Dark Sky Association (IDA) is committed to the preservation of our natural nocturnal environment, recognises the responsible use of light in the outdoors, and also designates Dark Sky Protected Areas such as star parks or nature reserves.

Only lights that meet the IDA criteria are suitable for use in protected dark sky areas:

- The lights have an Upward Light Output Ratio (ULOR) of zero percent, i.e. when installed they emit no light towards the sky - all technical outdoor lights, flat floodlights and the decorative outdoor lights in BlackEdition design keep up with this!
- The light may only have a low blue component. A maximum colour temperature of 3,000 K is permitted - no problem with the special light colours 2,200 K and 1,800 K (amber)!
- The amount of light should be controlled according to demand and reduced at night - easy to implement with the help of the LIMAS Air SYNC light management system from SCHUCH!

With our Dark Sky-compliant luminaires, we promote the spread of ecologically beneficial light and thus play our part in limiting light immissions. As a corporate member of the IDA and with our membership of the 'Vereinigung der Sternenfreunde e.V.', we are also sending out a further visible signal of our commitment.

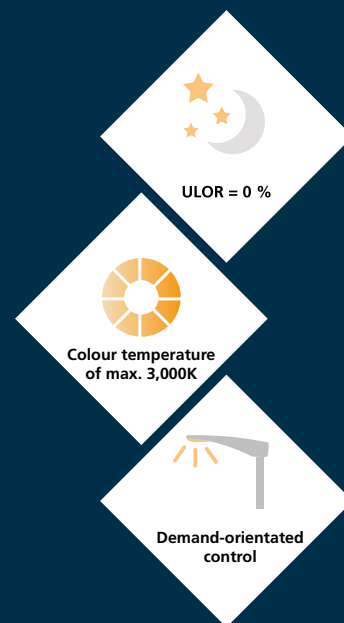

INTERNATIONAL DARK-SKY ASSOCIATION

BlackEdition – PROTECTING THE NIGHT SKY

With the redesign of our mushroom lights, we are taking a further step towards the sustainable product design of our entire outdoor lighting range.

We have placed particular emphasis on the following product features: simple modular design, tool-free replacement of ECG and LED module and no direct light emission into the upper half-space (ULOR = 0 %). The latter feature in particular gives this new generation its name: **BlackEdition**.

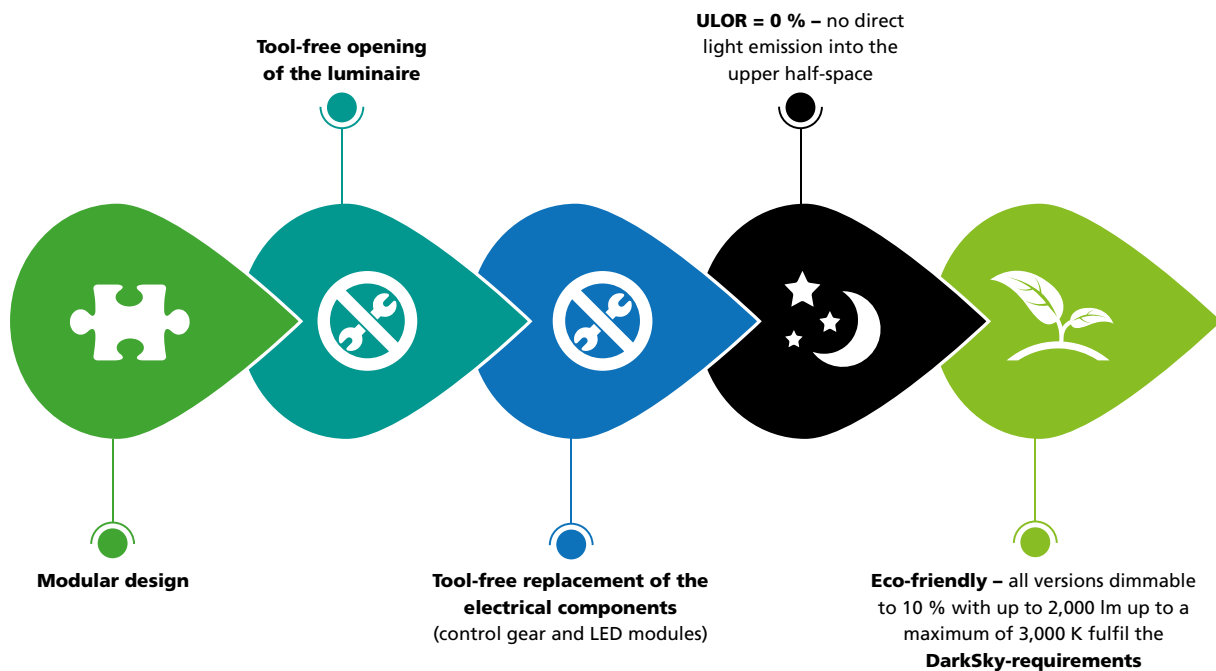

Modular design



Thanks to the modular design, the individual components can be replaced quickly and easily if necessary. The modular design also offers flexibility and adaptability: the luminaires can be adapted to specific requirements or future technical developments. This not only extends the service life of the luminaires, but also enables the different materials to be easily separated at the end of their service life.

Tool-free opening of the light



Installation, maintenance and fault rectification are particularly time-critical tasks for municipal street lighting. They affect traffic and can even lead to lane closures on one side and are not without danger for the installation personnel. Our BlackEdition luminaires can be opened without tools so that any work required can be carried out quickly and easily.

Tool-free replacement of electrical components



SCHUCH luminaires are not disposable products, but can always be maintained and repaired. The ECG and LED module can be replaced in no time at all without tools. This saves expensive labour time, reduces possible disruption to traffic to an absolute minimum and is an invaluable time and cost advantage, especially in the case of a planned group replacement.



ULOR = 0 %

Outdoor luminaires should be selected and positioned in such a way that disruptive light emissions into the environment are minimised or ideally avoided altogether. Our BlackEdition luminaires fulfil these requirements thanks to special optics with precise light control and shielding, among other things. The time- and demand-dependent controls and special light colours also help to effectively reduce disruptive light emissions.



Environmentally friendly

All 10% dimmable versions with luminous fluxes up to 2,000 lm and colour temperatures up to a maximum of 3,000 K meet the strict requirements of the International Dark Sky Association (IDA). BlackEdition luminaires therefore make a special contribution to protecting the night sky and minimising light pollution.

BlackEdition luminaires impress across the board. They fulfil our high standards of quality, efficiency and sustainability – extremely important factors when it comes to making a purchase decision.

In contrast to technical luminaires, where DarkSky requirements can be realised relatively easily, the re-design of our mushroom luminaires had to combine aesthetics with the protection of the night sky for the first time.

We have achieved this without compromise – see for yourself!



GreenLine – SUSTAINABLE PRODUCT DESIGN IN FOCUS

In general, the following can certainly be said: the higher the quality of a luminaire, the more sustainable it is. In detail, however, a multitude of criteria determine the degree of sustainability of a luminaire.

The Ecodesign for Sustainable Product Regulation (ESPR), which is expected in the future as part of the EU's "Green Deal", puts these sustainability aspects into concrete terms.

Green Deal



The European Union has set itself the goal of zero net greenhouse gas emissions by 2050. Europe is thus to become the first climate-neutral continent. To achieve this ambitious goal, comprehensive measures are planned in the areas of financial market regulation, transport, energy supply, industry, trade, agriculture and forestry. Existing legislation is to be adapted to the EU's climate goals.

Ecodesign Regulation



The Ecodesign Regulation 2019/2020 (EU) sets, among other things, energy efficiency requirements for lighting products. The aim is to increase the efficiency of energy-related products, strengthen the circular economy and recycling and thus make a significant contribution to increasing sustainability and reducing greenhouse gas emissions.

Taxonomy Regulation



The EU Commission's Taxonomy Regulation sets binding standards for sustainable business. This is intended to guide investment in sustainable companies and technologies and thus support the Green Deal. The EU Taxonomy establishes comparable and reliable sustainability indic

THE LABEL FOR OUTSTANDING SUSTAINABLE LUMINAIRES

GreenLine stands for outstandingly sustainable products in our range. For the classification of the luminaires, 13 verifiable and objectively measurable sustainability criteria are used, which are based on the expected future European ecodesign requirements for sustainable products and additionally take into account the **Taxonomy Regulation**, which is intended to promote six sustainability goals defined by the EU as central.



This is illustrated by the following criteria 1 to 9, which anticipate future requirements that will only have to be met in a few years' time and are already being implemented today. In addition to these nine basic requirements, criteria 10 to 13 define requirements for environmentally friendly packaging, service life, energy efficiency and light emissions. These are supplementary voluntary requirements that must be met by all GreenLine products. All criteria are regularly reviewed and adjusted if necessary.



BASIC REQUIREMENTS:

- 1 recycled material content $\geq 50\%$
- 2 decomposability at end of life
- 3 recyclability $\geq 80\%$
- 4 modular design
- 5 interchangeability of ECG and LED modules
- 6 use of standardised Zhaga-compliant LED modules
- 7 upgradeability
- 8 product guarantee at least 5 years
- 9 spare parts availability at least 10 years

ADDITIONAL REQUIREMENTS:

- 10 100% recycled paper packaging
- 11 long service lifetime L90 > 100,000 h for outdoor luminaires
- 12 high system efficiency > 140 lm/W for outdoor luminaires
- 13 ULOR = 0 for outdoor luminaires

Only lights from our range that fully fulfil all criteria are awarded the GreenLine label.

SCHUCH LIGHT FITTINGS: COMMITTED TO THE ENVIRONMENT



Sustainable use of materials

Only the use of material from secondary raw materials leads to true circular economy. Components that represent a high proportion of materials in the luminaires are particularly important. GreenLine products have a recycle content of at least 50 % in relation to the weight of the luminaire. For outdoor luminaires, recycle percentages of 70 % and more are achievable.



Recyclability

GreenLine light fittings are very easy to dismantle into their individual parts thanks to their consistently modular design. This makes it easy to separate the different materials for recycling at the end of the luminaire's service life. The parts are highly recyclable, resulting in a rate of over 80 %. The GreenLine products thus make a significant contribution to the conservation of valuable resources.



Repairability & easy replacement of components

GreenLine luminaires are not disposable products, but always repairable. All components are easily replaceable, often even completely without tools. This saves expensive working time during maintenance, reduces possible disruptions to production or traffic to an absolute minimum and is an invaluable time and cost advantage.



Maintenance-friendly

When developing our products, we pay special attention to ease of maintenance and installation. Ideally, control gear and LED modules as well as other components can be replaced without tools. Maintenance-friendly luminaires are cost-efficient and save resources. The simple exchangeability of sub-components also ensures a long useful life of the light fittings.



Upgradeability, retrofittability & expandability with smart functions

The modular design of the luminaires means that many things are possible with GreenLine products. For example, the use of Zhaga-compliant LED modules ensures the greatest possible flexibility in the use of efficiency upgrades and new LED generations. Standardised Zhaga sockets in the RFL luminaires, on the other hand, enable the use of sensors for autonomous or smart control with the aid of a light management system. Here, type and time can be freely selected. This flexibility and wide availability provides future and investment security.

High energy efficiency

GreenLine products are highly efficient. To keep the luminaires at the highest efficiency level, we always use the latest LED generations. In combination with extremely effective optics, the optimal and efficient solution for the respective requirement is achieved, maximum energy is saved and the CO₂ impact on the environment is reduced to a minimum.

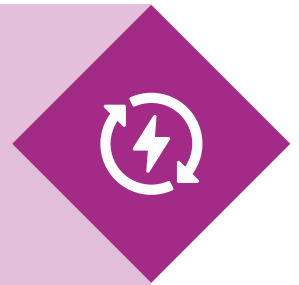

Long service life of the components & long duration of use of the luminaire

Thanks to the use of high-quality components from well-known brand manufacturers, GreenLine products have excellent service life values with L80>100,000 hours (for outdoor luminaires even L90 > 100,000 hours). With an average operating time of 4,200 hours per year for street luminaires, this corresponds to a period of almost 24 years. With 1-shift operation in the industrial sector, 34 years are achieved, with 2-shift operation at least 17 years and with round-the-clock operation still at least 11 years. However, the possible service life of a luminaire is considerably longer. To make use of this extremely long service life, all components are replaceable. This, and the low failure rate of electronic components, conserves resources, reduces waste and contributes significantly to the protection of our environment.



Long-term availability of replacement parts

The availability of spare parts for decades is standard at SCHCH luminaires. Due to the high vertical range of manufacture, the renunciation of commercial goods (all SCHUCH luminaires are in-house developments) and the co-operation with renowned brand suppliers, the control of spare parts availability is largely in our hands. Even after a series has been discontinued, we guarantee the supply of spare parts for a period of at least 10 years.



Guarantee

The quality of our products and the satisfaction of our customers is our highest priority. We therefore grant a five-year guarantee on all catalogue products with a rated service life \geq 50,000 hours. This quality promise stands for the quality of our luminaires, is valid from the date of invoice and is valid without registration. Of course also for all GreenLine products.



ULOR = 0 & Dark Sky

Luminaires for outdoor use must be selected and positioned in such a way that disturbing light emissions into the environment are kept to a minimum or, if possible, avoided altogether. All GreenLine luminaires for outdoor use fulfil this requirement. This is made possible, among other things, by special optics with precisely defined light control, shielding, time and demand-dependent controls as well as special light colours that effectively limit adverse light immissions. Only outdoor luminaires that emit no light into the night sky (ULOR = 0) and thus meet the strict specifications of the International Dark Sky Association (IDA) are awarded the GreenLine label.

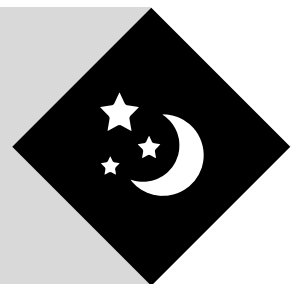

OPTICS

A wide range of lens optics is available for SCHUCH LED luminaires. This selection of different light distributions allows each lighting solution to be optimally adapted to the local conditions. The light distribution can be further optimised by adjusting the angle of inclination of the luminaire.

Special optics/light distributions are available on request for special requirements.

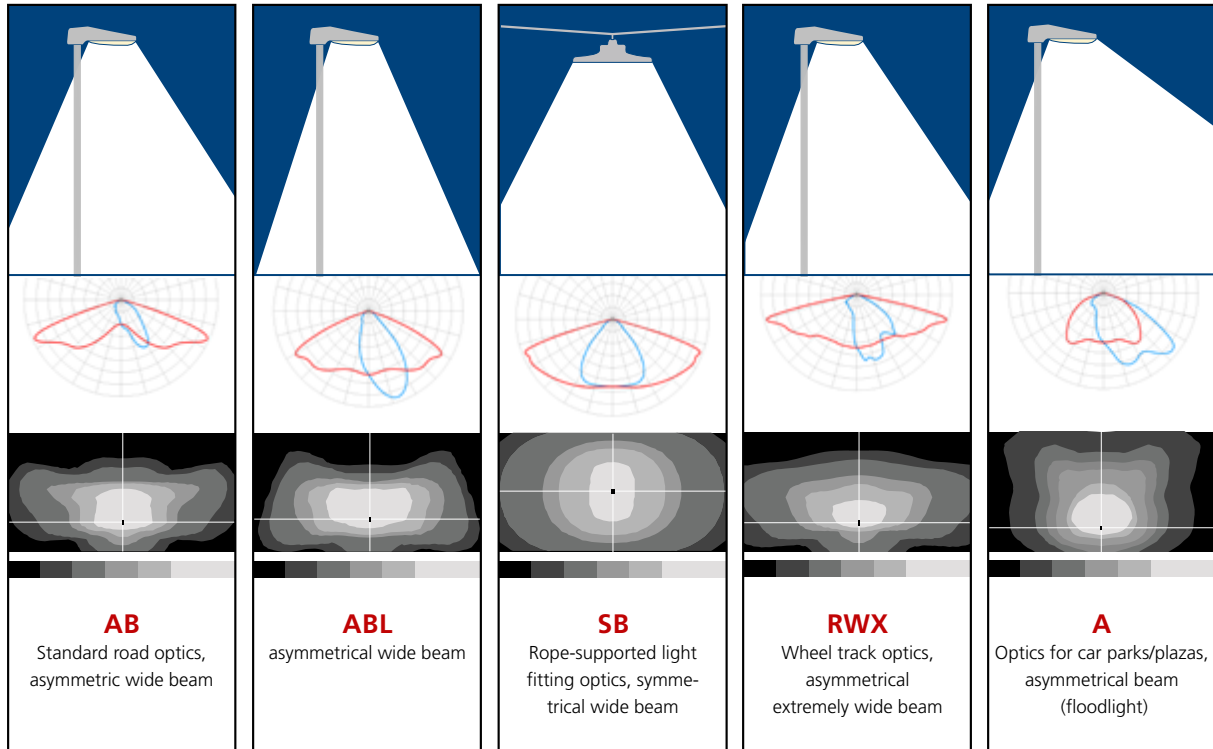

BACKSIDE LIGHT SHIELDING

The luminaires can be optionally equipped with backside light shielding to reduce light radiation to the rear and avoid disturbing light in the direction of buildings.



INCLINATION ANGLE ADJUSTMENT OF THE LED MODULES



Do you want to illuminate wide streets better, but don't want to do without decorative luminaires? No problem – with our new inclination adjustment, the LED module within the pole-top light fitting can be aligned accordingly!

All you need to do to tilt the LED module in 5° steps is loosen two screws.

This innovation can be realised with all classic SCHUCH pole-top light fitting, with the exception of the 544 series, and is listed under the option "With tilt adjustment (NV)".



ZHAGA-COMPLIANT LED MODULES

LED modules that comply with the Zhaga standard are used in all SCHUCH outdoor luminaires. This standardisation offers many advantages:

- Long-term security in the availability of spare parts regardless of the manufacturer of the luminaire
- Universal use in different SCHUCH luminaire series
- Greatest possible variety of light colours, luminous fluxes and light distributions
- The option to upgrade the luminaire to the latest LED generation is guaranteed over a long period of time without having to replace the entire luminaire

PAINTED COVER PLATES



AESTHETIC AND EFFECTIVE

For visual reasons, all technical outdoor lights are fitted with white painted cover plates that prevent the inside of the housing and the cabling from being seen. In addition to the aesthetic aspect, this also has a very practical advantage. The light-coloured surface reflects the light of the LED and increases the luminous flux of the luminaire by 3-5 %, depending on the configuration. In individual luminaire series, the covers also function as gear trays, which makes it extremely easy to replace components if necessary.

UNIVERSAL POLE ATTACHMENT

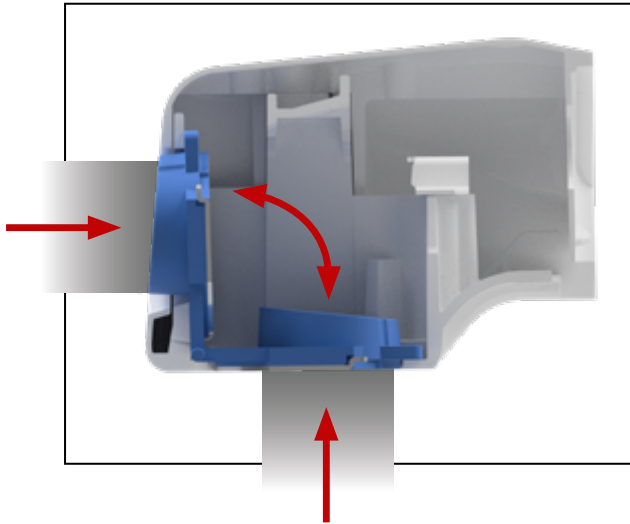

The proven SCHUCH universal pole attachment system made of die-cast aluminium enables flexible pole attachment and pole top mounting. Additional pole flanges or adapter pieces for the various pole diameters are not required. Adjustment to mast base or mast top mounting is made by simply flipping the cover flap without tools. The luminaire is then fixed to the pole using two grub screws. This makes it easy to adapt to the various pole spigot diameters (42 or 60 mm for pole base and 60 or 76 mm for pole top). Several screws in different lengths are included in the scope of delivery to optimise aesthetic aspects. Depending on the pole spigot diameter, this allows the screws to be flush with the cover flap and prevents the screws from protruding. An additional crescent-shaped cover visually closes the gap between the pole and luminaire body when mounted on top of the pole.

ADVANTAGES

- Adjustable to mast mounting or mast attachment without tools
- No additional mast flanges or adapter pieces required
- Suitable for all common mast spigot diameters

ESCAPE ROUTES / ASSEMBLY POINTS

Emergency lighting not only plays an important role indoors, assembly points and outdoor areas must also be appropriately illuminated in emergency situations

Our outdoor luminaires are therefore now also available in a ZB version (for connection to central supply systems), which fulfil the requirements for emergency luminaires in accordance with EN 60598 Part 2-22. This means they can easily be used in safety lighting systems in accordance with DIN EN 50172 VDE 0108-100:2024-10 or for illuminating outdoor escape routes and assembly points in accordance with DIN EN 838 and ASR A2.3.

ADVANTAGES

- **Increased safety and reliability:** Centralised safety power supply system(s) provide a central power source for multiple luminaires, reducing the likelihood of individual luminaires failing.
- **Easy maintenance and monitoring:** As the battery is centralised, the condition and performance of the battery is easier to monitor and maintain.
- **Reduces the risk of accidents:** Well-lit outdoor areas minimise the risk of accidents, especially in poor visibility conditions, such as at night or in bad weather conditions.



SEAWATER-RESISTANT VERSION

For use in regions close to the sea and areas with salty or corrosive atmospheres, the die-cast aluminium housing and pole mounting systems undergo a special surface treatment and are then painted. This ensures that the luminaire is permanently protected against the corrosive effects of salty air.



LIGHT COLOURS

○ 740 NEUTRAL WHITE (4,000 K, Ra >70)

The neutral white light colour with a colour temperature of 4,000 Kelvin has established itself as the standard light colour for outdoor areas due to its high efficiency and balanced colour perception, which is perceived as pleasant. However, with the growing importance of nature and environmental protection, the trend is increasingly moving towards warmer light colours.

● 730 WARM WHITE (3,000 K, Ra >70)

Due to its warmer appearance, this light colour with a colour temperature of 3,000 Kelvin has so far mainly been used in residential and residential streets, traffic-calmed zones and in old town areas. In the meantime, however, insect and nature conservation concerns are increasingly becoming the focus of attention and have a massive influence on the choice of light colour for public lighting. For example, according to the new municipal directive, from 2022 only outdoor luminaires with a maximum of 3,000 Kelvin will be eligible for funding. Laws and regulations on environmental protection and nature conservation at federal and state level will also drive the use of warm white light colours.

● 722 (2,200 K, Ra >70)

The light color 722, with a color temperature of 2,200 Kelvin, has a significantly reduced blue component compared to 3,000 Kelvin and comes closest to a high-pressure sodium lamp in terms of its colour impression. It is therefore ideal for retrofitting areas with existing luminaires that are illuminated with high-pressure sodium vapour lamps. At Ra > 70, the colour rendering is just as good as with the light colours 740 and 730. On crosswalks, the yellow light ensures high contrast and good visibility of the crossings if the surrounding street lighting is equipped with neutral white light colour. This increases motorised road users' awareness of these conflict zones and at the same time improves the safety of pedestrians.

● 518 AMBER (1,800 K, Ra >50)

The light spectrum of light colour 518 contains virtually no blue component and is therefore considered particularly insect-friendly. This light colour is therefore ideally suited for parks, the outskirts of settlements, areas close to bodies of water and roads and paths in ecologically valuable areas such as nature reserves and star parks, where the dark-sky aspect plays a particularly important role. The amber-coloured light, which creates a cozy atmosphere, is also very popular with residents and tourists when illuminating old town areas and illuminating structures and buildings.

EFFICIENCY & LIGHT COLOUR

The 4,000 Kelvin colour temperature has the highest efficiency (lm/W). The efficiency of the luminaire decreases with decreasing colour temperature.

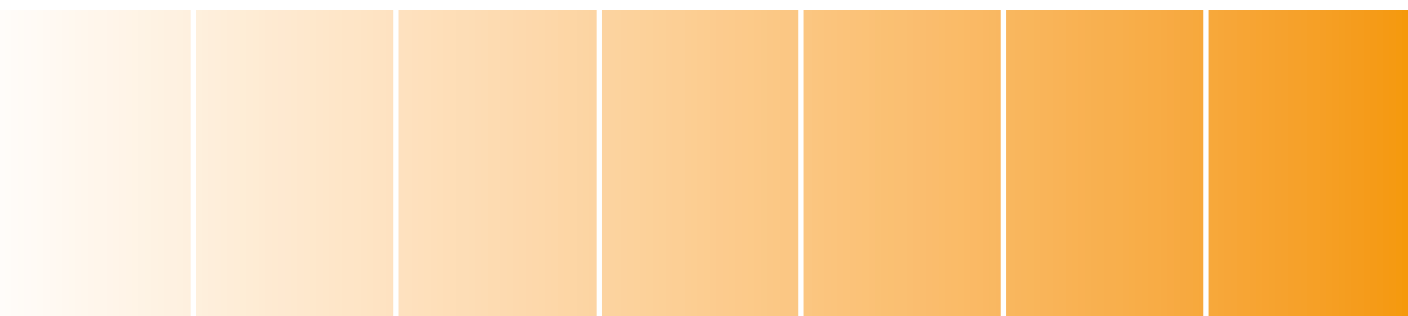
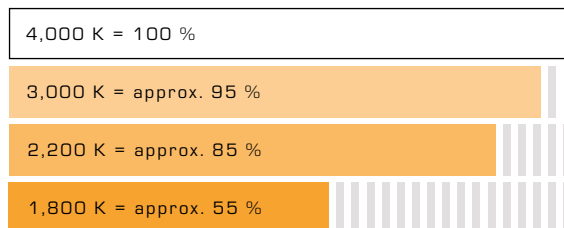

AMBER LIGHT FOR SENSITIVE AREAS

Areas where safety, ecology and quality of life are paramount deserve increased attention. Amber (light colour 518 = 1,800 Kelvin) is the magic formula here. A "yellow light" that meets the high requirements of these areas and counteracts light immission.

The Light of the Amber luminaire

- is scattered significantly less in fog than white light. This is because there is no blue component. The result is better visibility and therefore greater safety.
- is very insect-friendly due to the absence of blue light and is scattered much less into the night sky than white light. This not only benefits stargazers, but also has a positive effect on the entire ecosystem.
- is perceived as a warm light that creates an atmospheric and cosy atmosphere.



Better
visibility



Quality of life



Insect-
friendly



CONTROL FUNCTIONS

POWER REDUCTION WITH CONTROL PHASE (LR)

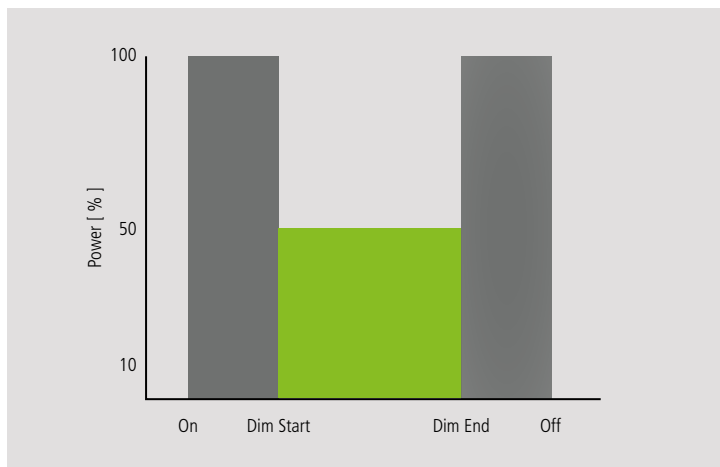

With this simple dimming function, 50 % of energy costs can be saved at night when there is little traffic (night-time dimming). For luminaires with power reduction, a control line is required. In the factory setting, the luminaire provides 100 % luminous flux when the control phase is applied. Without a control phase, the luminaire is dimmed to 50 %. The time until the lower dimming level is reached (usually 50 %), the so-called dimming ramp, can be programmed to up to 180 seconds (comfort function). The 100 % level is reached without a time delay.

Other dimming levels (10 % - 90 %) and an inverse function of the control phase (reduced operation 50 % with control phase applied) are optionally possible.

POWER REDUCTION WITHOUT CONTROL PHASE (LA)

If no control line is available, an independent power reduction can be used. The dimming profile can be selected individually, several dimming levels per night are possible. One dimming level (50 % luminous flux from 10:00 pm - 04:00 am CET and 11:00 pm - 05:00 am CEST) is set as standard. The time until the dimming level is reached (e.g. 50 %) can be programmed to up to 180 seconds (convenience function). The same applies to switching back to 100 %. This gradual lowering or raising of the luminous flux means that the switchover is not visually perceptible. It therefore serves the comfort of the user, as disruptive influences on road users or residents are avoided.

Control via a timer should not be used, as the luminaires would then not dim at the programmed times.

The dimming times can also be specified individually. As these are parameterised in the luminaire's control gear, they can only be considered if they are communicated at the

time the order is placed. The light dims completely automatically to the various dimming levels at the specified times. As the luminaire does not use a real-time clock as a timer, the actual dimming times are recalculated each night from the previous switch-on and switch-off times.

A changeover to summertime is therefore neither necessary nor possible. Time deviations are ruled out even after decades of operation.

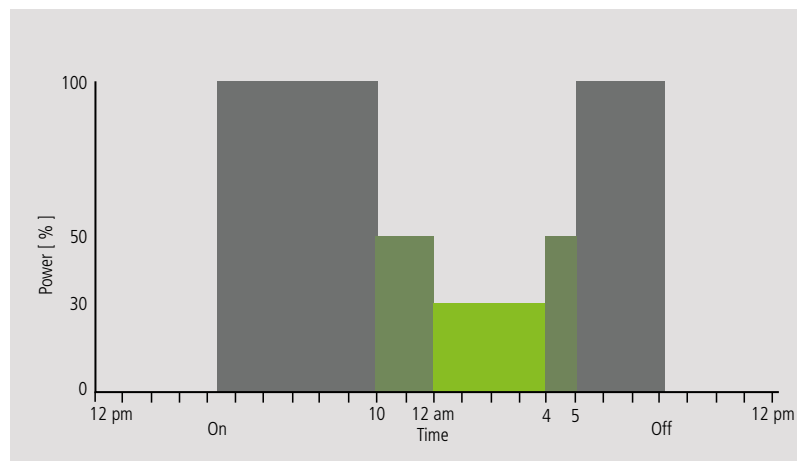

DALI DIMMING FUNCTION DIMD

DIMD luminaires use a DALI control gear. They can therefore be very easily integrated and controlled in an existing or planned DALI structure or a Powerline light management system. For this purpose, the DALI connections of the luminaire must be routed mains voltage-free to the cable junction box.



CONSTANT LUMINOUS FLUX FUNCTION (CL)

The CL function has the task of keeping the luminous flux constant at the required level (L value = L_{100}) during the service life of the luminaire. Precisely controlled readjustment of the power compensates for the degradation in luminous flux. The output increases from the initially set 90 % to a maximum of 100 % at the end of the service life.

Advantage: Only as much energy is consumed as is necessary to always maintain the required lighting level. The usual oversizing of the luminous flux is avoided, and additional energy is saved (compared to a version without CL).

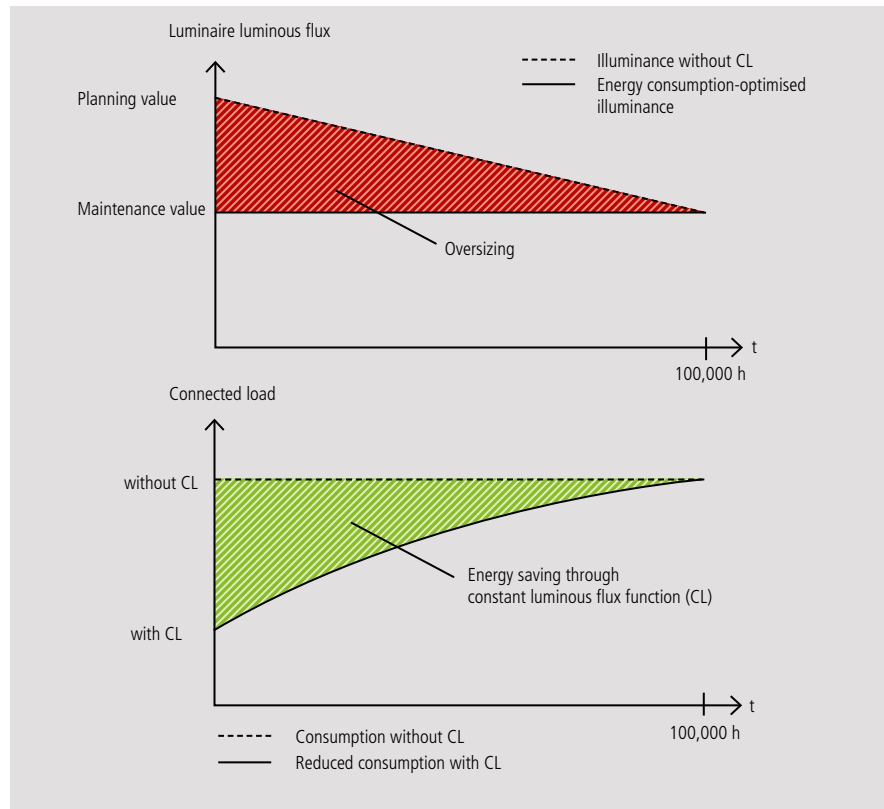



ECOTUNE

Good lighting must meet many requirements: ensure the safety of road users and residents, increasingly take ecological aspects into account and offer urban planner's opportunities to make inner city areas more attractive. Static lighting does not meet these require-

ments. Adaptive systems, on the other hand, with which lighting can be flexibly adjusted to changing situations, offer many forward-looking solutions.

CHANGE OF THE LIGHT COLOUR

People and nature should not be affected by artificial light any more than is absolutely necessary. This is achieved with the help of colour-changing, controlled light. In this way, the right amount of light and light colour can be provided in each case, which also respects the nocturnal ecosystem ("insect mode"). For this purpose, two different light colours are combined in one luminaire, for example neutral white with 4,000 K and the more nature-friendly light colour 2,200 K. By changing the mixing ratio of the two light colours, the light emitted in the quieter evening and night hours can be changed to a warmer, more pleasant light. In the morning hours, on the other hand, the proportion of neutral white light colour is increased again, resulting in a brighter and higher-contrast light in order to

meet the higher safety requirements of increasing traffic. The multi-layer principle, in which each individual LED illuminates the entire surface, guarantees that there is always uniform illumination, regardless of the respective light colour combination.

The light can also be controlled in conjunction with motion sensors. At times when the lighting is reduced or dimmed, the presence of people or vehicles causes the luminous flux to be increased (and then reduced again) in order to meet security requirements.

ADVANTAGES

- Independent adjustment of light colour and luminous flux
- Neutral white light in the early evening and morning enables good contrast vision and increases the attention of road users.
- Warm and dimmed light in the deep hours of the night helps residents to sleep, is particularly insect-friendly and minimises light emissions into the night sky
- Smooth transition between colour temperatures
- Multi-layer principle guarantees uniform illumination of the entire surface in the respective light colour combination.
- light colours can be combined according to customer requirements.
- Illuminance and dimming profile can be programmed on a customer-specific basis

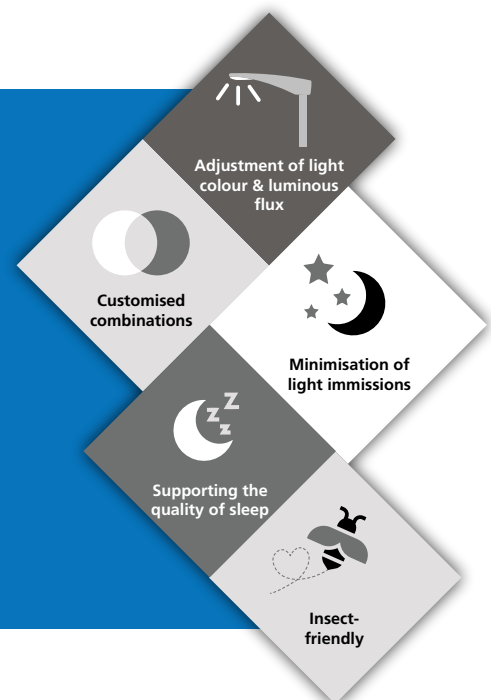

COLOUR COMBINATION

standard version STREET (colour temperature 4,000-2,200 Kelvin)

Autarkic power reduction (LA)
3 dimming levels

until 8:00 p.m.	100 %	4,000 K
8:00 pm - 2:00 p.m.	70 %	3,000 K
10:00 pm - 04:00 a.m.	50 %	2,200 K
4:00 am - 06:00 a.m.	70 %	3,000 K
from 06:00 a.m.	100 %	4,000 K

Dimming ramp 180 seconds

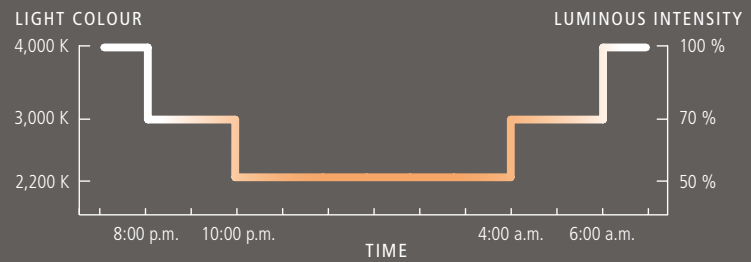

INDUSTRY version (colour temperature 6,500-3,000 Kelvin)

Traffic areas in industrial zones are illuminated in high-contrast cool white and switched to nature-friendly warm white at night.



ENVIRONMENT version (colour temperature 3,000-1,800 Kelvin)

Parks, riverside promenades and natural areas are illuminated in 3,000 Kelvin at dusk and switched to particularly insect-friendly amber light late in the evening.



Version CUSTOM (Combination of any 2 light colours according to customer requirements)

OPTIONS

- Control via motion detector
- Control via RFL or LIMAS Air SYNC light management system
- Example: Cycle path
basic lighting 20% in 1,800 or 2,200 Kelvin, when motion is detected, increase to 100 % and 3,000 or 4,000 Kelvin, moving light (light on demand).

CHANGING THE LIGHT DISTRIBUTION

Bad weather, such as rain, fog or snow, can be a problem for road users. In addition to impairing visibility and thus the perception of other road users, wet roads in particular can cause significant glare.

Adapting the light distribution to changing weather conditions, i.e. using luminaires with two different optics, can be a solution. Wide-beam light distribution on dry roads and narrow-beam light distribution on wet roads can help to reduce glare and therefore increase road user safety.

Whether such a solution makes sense in individual cases can only be discussed in a detailed consultation.

However, the normative requirements for both dry and wet road surfaces are already met by both our AB optics and the low-glare ABL optics.



THE VARIO CONCEPT

No luminaire combines as many advantages in a single type as a VARIO. High-quality and efficient, it offers a unique advantage that guarantees maximum flexibility and economy - variable adjustment of the luminous flux. The luminous flux can be adjusted almost infinitely as required. And not just during initial installation. The setting can also be changed later at any time to adapt the lighting to individual requirements. Be it because the lighting requirements change or

simply because the lighting is perceived as too bright or too dark. This flexibility is maintained over the entire service life and enables optimum energy cost and CO2 savings to be made depending on the situation. The setting itself is very simple and tool-free using the DIP switch integrated in the luminaire. If you wish, you have a wide range of setting options and can select the luminous flux to suit your individual requirements. The most common settings are

indicated on a sticker, with details of which conventional versions they replace. This means that the lighting can be perfectly adapted to any situation with just one type of luminaire. With a VARIO, you always have the right light at hand.

THE MOST IMPORTANT BENEFITS AT A GLANCE

Variably adjustable luminous flux

- almost infinitely variable
- tool-free
- changeable at any time

Universal use

- a single type instead of many variants
- always the right luminaire on hand
- perfect adaptation to any need

Maximum economy

- light exactly as required
- maximum energy savings
- Optimised warehousing and spare parts procurement

The most common settings

Example: 48 L50 VARIO

	1	2	3	4	5	6	7	8	Power	replaced
on off	■	■	■	■	■	■	■	■	9 W	HME50 HST35
on off	■	■	■	■	■	■	■	■	15 W	HME80 HST50
on off	■	■	■	■	■	■	■	■	18 W	HME125 HST70
on off	■	■	■	■	■	■	■	■	35 W	2xHST70

STANDARD VERSION

High quality

- ▶ longer service life, **highest reliability**
- ▶ repairable and upgradeable **longer service life**
- ▶ **long-term availability** of spare parts

High efficiency

- ▶ **lower energy costs**
- ▶ **shorter amortization times**
- ▶ **lower CO₂-emissions**

VARIO VERSION

Additional advantages

- ▶ **variable adjustment of the luminous flux**
- ▶ always as required, therefore **maximum energy saving**
- ▶ Changed requirements: **multiple use** instead of disposal

**SUSTAINABLE, ENVIRONMENTALLY
FRIENDLY & RESOURCE-SAVING**



VARIO NFC



For LED luminaires in the VARIO NFC version, the luminous flux is set using a smartphone app (for iOS or Android) via NFC (Near Field Communication), which can be done before installation in a de-energised state. In the LA versions (with power reduction without control phase), the power reduction can also be parameterised with different times and levels.

The link to the app can be found in the installation instructions. The integrated NFC interface can be used for parameterisation on smartphones with Android 8 and higher. For trouble-free communication, however, we recommend the use of a Bluetooth/NFC adapter, which is available as an accessory.

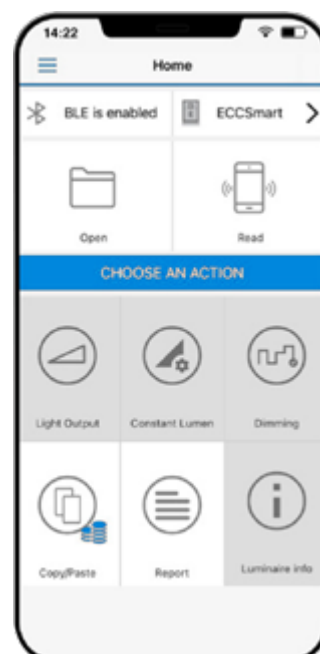

RFL LUMINAIRES

When is the right time to implement a light management system? Right at the replacement of the conventional lighting or should you rather wait a few more years?

Our RFL luminaires, that are prepared for retrofitting light management components, keep all options open for the future. Timing is yours.

CONCEPT „READY FOR LIGHT MANAGEMENT SYSTEMS”

One or two Zhaga Book 18 (Z18) compliant sockets with D4i control gear integrated into the luminaire housing enable the subsequent, tool-free installation of the necessary components such as controllers, radio antennas and sensors. The use of autonomous sensors without connection to a light management system is also possible at any time. RFL luminaires are available in various series and product ranges, such as outdoor or indoor luminaires. The product range is

being continuously expanded.

Thanks to the standardisation of sockets in accordance with Zhaga Book 18 (Z18), you are not tied to our LIMAS Air light management system, but can choose freely from all manufacturers who also use standardised Zhaga socket connections.

Advantages















- Standardised Zhaga Book 18 (Z18) compliant sockets with D4i control gear in the luminaire housing
- Light management system can be added at any time
- Quick, tool-free installation of light management system components



System components

RFL LASC DS	Controller for radio control of RFL luminaires (2.4 GHz mesh network) with photocell (twilight switching)	
RFL LASC DS GPS SIM	Controller for radio control of RFL luminaires (2.4 GHz mesh network) with GPS antenna (automatic luminaire position determination) and photocell (twilight switching), with integrated SIM card for connecting up to 100 adjacent nodes to the cloud. Enables remote configuration / commissioning and monitoring of the system, and provides timing in the system (GPS)	
RFL LASC BM RAD8	Controller for radio control of RFL luminaires (2.4 GHz mesh network) with integrated radar motion sensors, maximum mounting height 8.0 m	
RFL LASC BM RAD10 MA MK2	Controller for radio control of RFL luminaires (2.4 GHz mesh network) with integrated radar motion sensors, designed for pole mounting, maximum mounting height 10.0 m	
RFL BM RAD12	Radar motion sensor for RFL luminaires with mounting heights up to max. 12.0 m - only permitted in conjunction with RFL radio control (article RFL LASC DS und RFL LASC DS GPS SIM)	
RFL BM/DS IR8	Infrared motion sensor for RFL luminaires with mounting heights up to max. 8.0 m - only permitted in conjunction with RFL radio control (article RFL LASC DS und RFL LASC DS GPS SIM)	
RFL BM/DS IR12	Infrared motion sensor / twilight sensor for RFL luminaires with mounting heights up to max. 12.0 m, suitable for standalone operation or for use in combination with RFL radio control (article RFL LASC DS und RFL LASC DS GPS SIM), compatible accessory: shielding mask for limiting the detection area	
RFL DS20	Twilight sensor for autonomous control of RFL luminaires. Use in conjunction with other system components not permitted	

Operating modes

Operating modes		Radio networking	Motion detection	Twilight switching	Time-based control	Programm-ing	Connection to the cloud
1	RFL LASC DS GPS SIM	✓	✗	✓	✓	 	✓
	+ RFL BM/DS IR8	✓	✓	✓	✓	 	✓
	+ RFL BM RAD12	✓	✓	✓	✓	 	✓
	+ RFL BM/DS IR12	✓	✓	✓	✓	 	✓
2	RFL LASC DS	✓	✗	✓	Optional with article 1		Optional with article 1
	+ RFL BM/DS IR8	✓	✓	✓	Optional with article 1		Optional with article 1
	+ RFL BM RAD12	✓	✓	✓	Optional with article 1		Optional with article 1
	+ RFL BM/DS IR12	✓	✓	✓	Optional with article 1		Optional with article 1
3	RFL LASC BM RAD8	✓	✓	Optional with article 1 or 2	Optional with article 1		Optional with article 1
4	RFL LASC BM RAD10 MA MK2	✓	✓	Optional with article 1 or 2	Optional with article 1		Optional with article 1
5	RFL BM/DS IR12	✗	✓	✓	✗		✗
6	RFL DS20 *	✗	✗	✓	✗	✗	✗

 USB dongle

 Cloud connection

 Standard sensor programming, can be customised ex works

* * runs independently and cannot be combined with other components



LIGHT MANAGEMENT

Light only where it is needed, only when it is essential, only as bright as necessary and only as long as it is required - with the help of a Light Management System, the efficiency potential of LED technology can be optimally exploited.

Intelligent, demand-controlled light saves a great deal of energy costs and is extremely environmentally friendly and sustainable thanks to the considerable reduction in CO₂ emissions associated with it. In addition, the networking of the light points opens up a wide range of options.

Digital lighting, networking and intelligence can be approached in stages. From simple control via DALI luminaires to complex light management. SCHUCH always offers the right lighting solution for individual needs: whether wired or radio-controlled, permanently installed or upgradeable.



RADIO-BASED LIGHT MANAGEMENT SYSTEM for outdoor light and smart city applications



Our LIMAS Air SYNC light management system allows a demand-based, intelligent control of lighting on streets, squares, parks and industrial areas. Even complex smart city projects can be easily implemented. The system enables wireless control and grouping of luminaires via a self-organising mesh network. Cloud connectivity is optional and can be implemented using special controllers. Integrated eSIM communication ensures

secure data exchange with the cloud. The mesh network can also operate completely independently of the cloud, which is particularly advantageous for critical infrastructures.

Eigenschaften / Funktionen:

Technology	Radio-based (2.4 GHz, mesh network / cloud / eSIM)
Control	Cloud-based, via sensors, buttons or time profiles
Communication	Radio-based mesh communication, optional eSIM for cloud integration
Operation	Web interface via browser
Installation	No additional control line required
Visualisation	Map or list view with status display of all lights
Special feature	Smart city-compatible system with light-on-demand function

System components

LASC DONGLE USB + SOFT + LIZ	USB radio adapter including software and license for on-site setup / programming of LIMAS Air SYNC systems	
LASC SENSBOX	External unit with integrated radio module (2.4 GHz mesh network) for integrating various functions into a LIMAS Air SYNC system (compatible with LIMAS Air SYNC controllers)	

SYSTEMVERSIONEN

Version with USB dongle (stand-alone solution, no cloud connection)

With this system solution, the luminaires can be programmed and read out on site in the field using a USB dongle and Windows PC / tablet.

The luminaire parameters such as dimming level, run-on time and behaviour in the event of motion detection are stored in the radio controls / controller. The luminaires can be operated without a connection to the USB dongle. Both items also each contain a photocell for a twilight switch. Here, one controller is defined as the master

brightness sensor in the field, which transmits the correspondingly measured brightness value to all other controller in the field (slave).

At least one controller is required for time-accurate switching via the light management system. This HUB supplies the integrated GPS antenna and the connection to satellites in the neighbourhood the exact time and forwards it to neighbouring controller via radio.

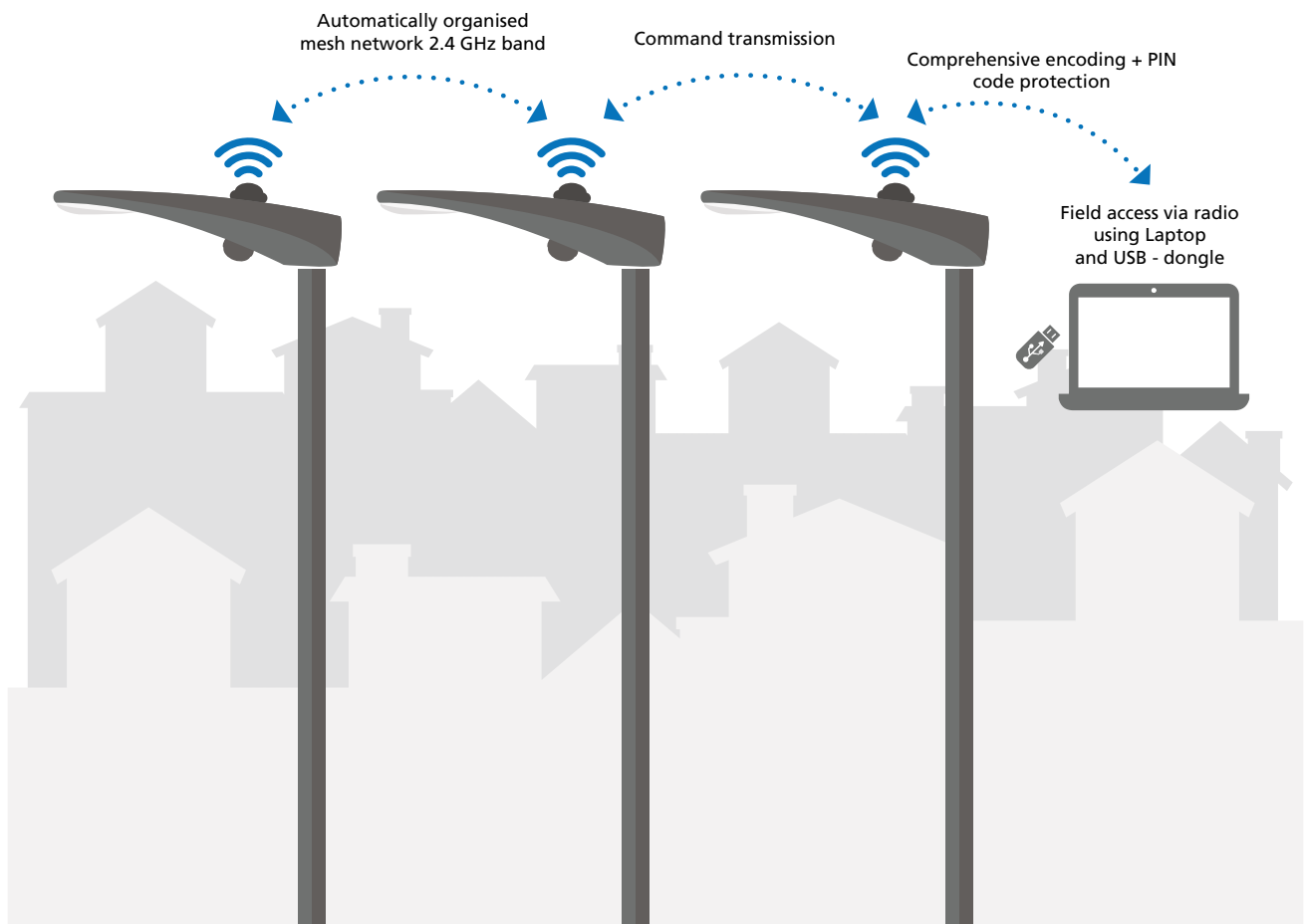



Version with RFL LASC DS GPS SIM (cloud connection)

With this system solution, the luminaires can be programmed, read out and monitored remotely using cloud access via any Internet browser and any operating system. 5 The RFL LASC DS GPS SIM 1 uses its integrated SIM card 2 to wirelessly connect neighbouring controller 3 into the cloud. 4

The RFL LASC DS GPS SIM uses the integrated GPS antenna and the connection to satellites in the vicinity to provide the exact time and and forwards this to neighbouring controller via radio. The exact position is also recorded using satellite technology. 1)

The luminaire parameters such as dimming level, run-on time and behaviour in the event of motion detection are stored in the radio controller. The controller of the luminaires therefore continue to

work independently even without a connection to the cloud. Both items each contain a photocell for twilight switching. Here, one HUB is defined as the master brightness sensor in the field, which transmits the correspondingly measured brightness value to all other controller in the field (slave).

Automatic location detection is only available for GPS-enabled controllers. Controllers without an integrated GPS module require manual positioning within the map view.

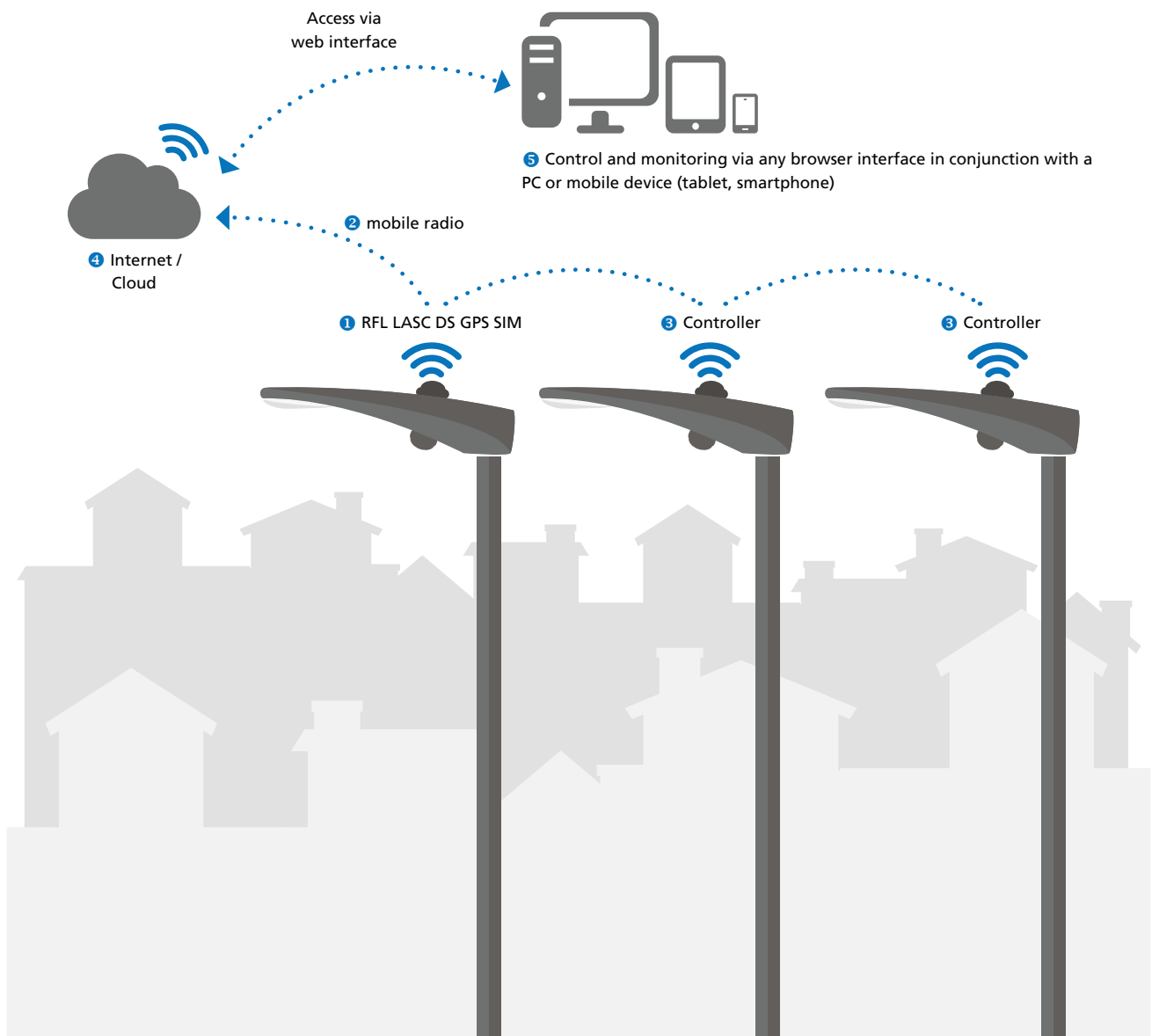

MOTION DETECTION (LIGHT ON DEMAND)





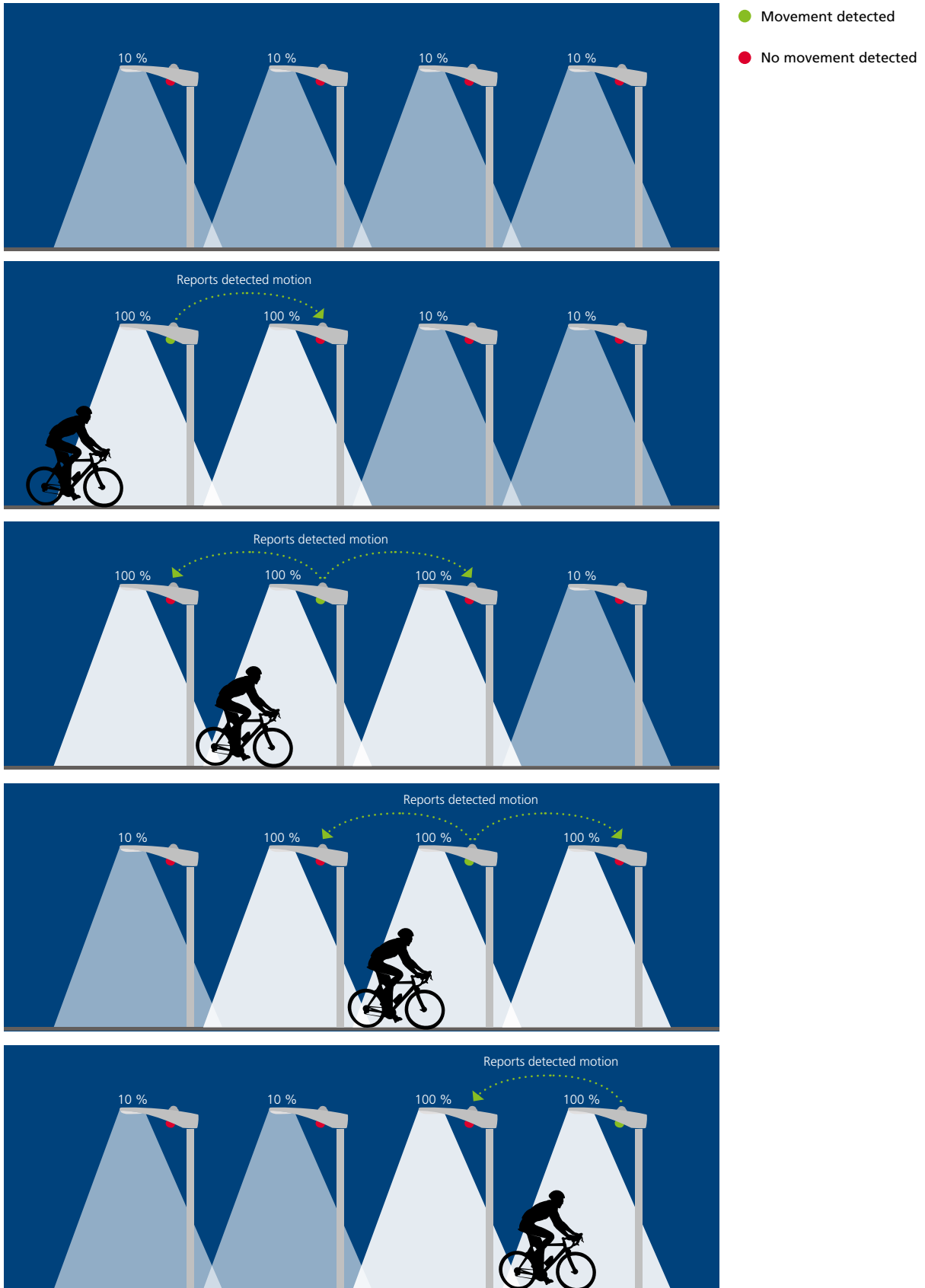







If a road user passes an RFL luminaire with Controller and motion sensor, this is detected by the motion sensor and, depending on the programming, the luminaire switches from background level 10 % to 100 % illuminance with a defined follow-up time, e.g. 1 minute.

Neighbouring luminaires can be linked via the light management system in order to set up a leading light. As soon as a motion sensor of a luminaire detects an object in conjunction with a radio control system, the neighbouring luminaires in the street are also switched to a higher lighting level via radio.



FUNCTIONAL SCOPE

The LIMAS Air SYNC system offers a wide range of functions for needs-based lighting control and comprehensive monitoring of the luminaires. Thanks to the intuitive user interface, system settings can be easily adjusted and analyses quickly called up.

		USB DONGLE	CLOUD CONNECTION
	User-friendly user interface with graphic display of operating status, energy consumption, function and location of the light fittings	●	●
	Freely configurable dimming profiles according to time, dimming level and motion profile	●	●
	Real-time access to the luminaires for instant-on or changing dimming profiles if necessary	●	●
	Integrated constant luminous flux function to keep the luminous flux constant over the entire service life	●	●
	Energy consumption metering	●	●
	Evaluation and export of selected or saved luminaire data	●	●
	Access to all system functions at any time and from any place in the world		●
	Automatic error messages by e-mail or SMS with location information		●
	Time and date updates via time server for time-dependent dimming	opt.	●
	Motion detection via motion sensor (PIR sensor)	opt.	opt.
	Optimised on/off with daylight sensor	●	●
	Time, date, parameter and position monitoring via GPS ¹	opt.	●

opt. = optional

¹ Automatic position detection only for GPS controllers; standard controllers are set manually.



VIA

SERIES 51 / 52



The VIA is an excellent example of sustainable product design. Modular in design, highly energy efficient, durable, pollutant-free, with 100 % recycled content in the die-cast aluminium housing and of outstanding quality and reliability, the light fittings combine modern design with highly efficient technology and sustainable construction. All components, including the LED modules, can be replaced without tools. Standardised modules and components, standardised interfaces/sockets for expanding the light fittings with light management systems and

sensors (RFL concept) make the VIA retrofitable and upgradeable. Long-term availability of spare parts also provides future and investment security.

The VIA also impresses in terms of ease of installation with well thought-out solutions for fast and convenient working. Everything has been thought of, from the central lock that can be opened without tools to the universal mast adapter for mast mounting and mast attachment (60 and 76mm), which is already pre-mounted on the light fittings for mast mounting.

Do you want to save as much energy as possible and protect the environment? With versions for variable adjustment of luminous flux (VARIO), the LIMAS Air SYNC light management system, RFL types and variants for changing the light colour / distribution (EcoTune), all options are open to you.

VIA – a modern, sustainable LED streetlight that you will enjoy for a long time.



ADVANTAGES

- Long-lasting, corrosion-resistant die-cast aluminium housing with smooth surface without cooling fins
- Quick and easy mounting due to toolless opening of the light fitting by means of a central toggle clamp lever
- No uncomfortable "working overhead", light fitting opens upwards
- Pre-assembled universal pole attachment for pole spigot 60 and 76 for pole attachment or pole top mounting
- Easy insertion of the cable into the terminal compartment due to cable gland
- Tool-free exchange of the LED board (carrier plate, disconnect plug, clamping spring) as well as ECG exchange (carrier plate, disconnect plug, clamping spring)
- Time- and cost-saving component replacement at the end of service life or retrofitting in the event of further technical development or the use of other/warmest light colours
- Homogenous illumination due to Multi-Layer Technology
- Integrated pressure compensation system prevents condensation inside the light fitting
- No light emission into the upper half space. ULOR = 0
- Eco-friendly; versions dimmable to 10 % and with color temperature up to 3,000 K comply with Dark Sky requirements
- Sustainable, components tool-free interchangeable
- Future proof by using standardised Zhaga LED modules
- GreenLine luminaire, outstanding sustainable design

Main uses

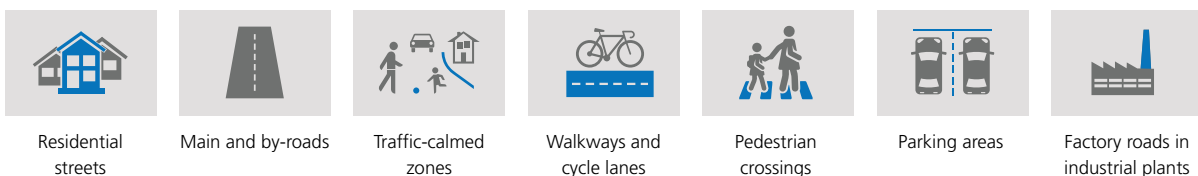

Die-cast aluminium housing, powder coated DB 702 (micac-iron), smooth surface, no dirt deposits

Silicone seal can be replaced without tools

LED module carrier made of painted aluminium, can be replaced without tools

LED module highly efficient, long-lasting high-power LED modules. Zhaga conformity ensures long-term availability of standardised replacement modules

Optics highly efficient lens optics for optimum light distribution

DIP switch on VARIO version for setting the luminous flux without tools

ECG high-quality and durable with high surge voltage resistance of 10 kV

ECG gear tray can be replaced without tools

Isolating plug enable tool-free replacement of LED module carrier and ECG gear tray

Bracket for securing the open housing

Flat safety glass, replaceable

Die-cast aluminum central lock can be opened without tools

Isolating plug for disconnecting the light from the power supply without tools

Pressure equalisation system to prevent condensation in the interior

Universal mast connector, for mast braid Ø60/70 mm for mast top or mast base mounting, pre-assembled with 0° inclination for mast top mounting



Video:
Assembly and
component
replacement



COMPLETELY TOOL-FREE COMPONENT REPLACEMENT

Installation, maintenance and fault rectification are particularly time-critical tasks for municipal street lighting. They affect traffic to the point of blocking half of the carriageway and are not without danger for the installation personnel. This work should therefore be carried out as quickly as possible in order to minimise costs.

VIA is absolutely exemplary here.

The universal pole bracket for 60 mm and 76 mm pole spigots is already pre-assembled on the luminaire when it is delivered. On request, the connection cable can also be connected in the desired length at the factory, so that the installation time can be reduced to a minimum. Replacing components is even quicker, as the entire process is carried out in a few simple steps and, above all, completely without tools. It couldn't be simpler or quicker.

- Tool-free opening of the light via a central toggle lock
- Tool-free operation of the disconnect plug
- Tool-free removable ECG unit
- Tool-free removable LED gear tray
- ESD protection measures not required (touch-safe design)

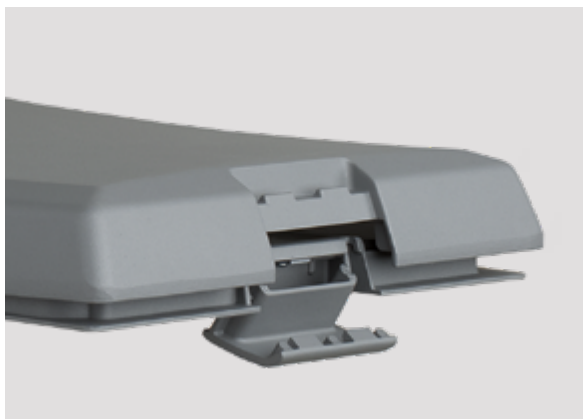

TECHNICAL PROPERTIES

Series 51 VIA

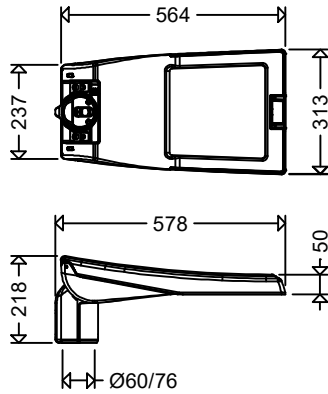

Series 52 VIA

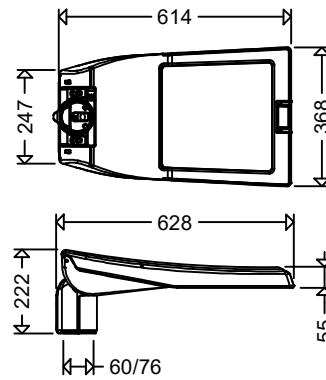

All light fittings also available with connected cable (H07RN-F or NYM) in the required length.

	51 VIA	52 VIA
Recommended mounting height	4 - 10 m	5 - 12 m
Wind-exposed surface	0.05 m ²	0.05 m ²
Luminous flux (LF 740)	1,490 - 16,270 lm	9,060 – 26,520 lm
Luminous flux (LF 740)VARIO / NFC	1,330 - 16,270 lm	4,190 – 26,520 lm
Luminous flux (LF 730)	1,420 - 15,460 lm	8,610 – 25,190 lm
Luminous flux (LF 730) VARIO / NFC	1,260 - 15,460 lm	3,980 – 25,190 lm
Connected load	9 - 70 W	52 - 140 W
Connected load VARIO / NFC	9 - 106 W	24 - 140 W
Luminous efficiency (LF 740)	153 - 173 lm/W	152 - 177 lm/W
Luminous efficiency (LF 740) VARIO / NFC	148 - 175 lm/W	152 - 179 lm/W
Luminous efficiency (LF 730)	146 - 165 lm/W	144 - 168 lm/W
Luminous efficiency (LF 730) VARIO / NFC	140 - 167 lm/W	144 - 170 lm/W
Optics	AB, ABL, RWX, A	
Light colours	740, 730, 722, 518	
Control functions	LR, LA, CL, DIMD , EcoTune	
Light management	LIMAS Air SYNC, RFL	
Variable luminous flux setting	VARIO / NFC	
IP rating	IP66	
Protection class (standard/option)	II / I	
ECG	220 - 240 V, 50 - 60 Hz	
IK rating	10 kV	
LED module	Highpower, Zhaga compliant	
Service life	L90 > 100,000 h at max. temperature	
Energy efficiency class	B	

Options:

Seawater-resistant version, bird deterrence, backside light shielding, for connection to a central power supply system, additional overvoltage protection, inrush current limiter, special painting in RAL colours

MAXIMUM EFFICIENCY OR LOWEST INVESTMENT COSTS

When solving your lighting task, you often have the choice between maximum energy efficiency and the lowest initial investment. Compare and choose the optimum solution for your project.

The standard versions of the series are listed in the table. Customised lumen packages can be programmed at the factory.

Standard types

asymmetrical wide distribution

Type	Connected load [W]	Luminous flux [lm]		Luminous efficiency [lm/W]		Weight [kg]
		LF 740	LF 730	LF 740	LF 730	
51 0801	9	1,490	1,420	166	158	8.0
51 0802	13	2,080	1,980	160	152	8.0
51 0803	18	2,810	2,670	156	148	8.0
51 1601	17	2,900	2,760	171	162	8.0
51 1602	25	4,050	3,850	162	154	8.0
51 1603	35	5,480	5,210	157	149	8.0
51 2401	26	4,470	4,250	172	163	8.1
51 2402	37	6,200	5,890	168	159	8.1
51 2403	53	8,340	7,920	157	149	8.4
51 3201	34	5,890	5,600	173	165	8.5
51 3202	50	8,170	7,760	163	155	8.5
51 3203	70	10,950	10,400	156	149	8.5
51 4801	52	8,770	8,330	156	149	8.6
51 4802	75	12,150	11,540	162	160	8.6
51 4803	106	16,270	15,460	153	154	8.6
51 L50 VARIO / NFC	9	1,330	1,260	148	146	8.5
	15	2,510	2,380	167	159	8.5
	18	3,090 ¹⁾	2,940 ¹⁾	172	163	8.5
	35	5,480	5,210	157	149	8.5
51 L100 VARIO / NFC	16	2,720	2,580	170	161	8.6
	38	6,660	6,330	175	167	8.6
	54	8,890 ¹⁾	8,450 ¹⁾	165	156	8.6
	70	10,950	10,400	156	149	8.6
51 L150 VARIO / NFC	24	4,050	3,850	169	160	8.6
	45	7,600	7,220	169	160	8.6
	82	13,230	12,570	161	153	8.6
	106	16,270 ¹⁾	15,460 ¹⁾	153	146	8.6

Type	Connected load [W]	Luminous flux [lm]		Luminous efficiency [lm/W]		Weight [kg]
		LF 740	LF 730	LF 740	LF 730	
52 4801	52	9,060	8,610	174	166	10.7
52 4802	75	12,550	11,920	167	159	10.7
52 4803	106	16,730	15,890	158	150	10.7
52 6401	69	11,930	11,330	173	164	10.8
52 6402	99	16,490	15,670	167	158	10.8
52 6403	140	21,980	20,880	157	149	10.8
52 8001	86	14,530	13,800	169	160	11.0
52 8002	124	20,000	19,000	161	153	11.0
52 8003	175	26,520	25,190	152	144	11.0
52 L150 VARIO / NFC	24	4,190	3,980	175	166	10.7
	45	7,870	7,480	175	166	10.7
	82	13,640	12,960	166	158	10.7
	106	16,730 ¹⁾	15,890 ¹⁾	158	150	10.7
52 L210 VARIO / NFC	32	5,520	5,240	173	164	10.8
	79	13,490	12,820	171	162	10.8
	99	16,490	15,670	167	158	10.8
	140	21,980 ¹⁾	20,880 ¹⁾	157	149	10.8
52 L250 VARIO / NFC	37	6,750	6,410	182	173	11.0
	93	15,460	14,690	166	158	11.0
	137	21,730	20,640	159	151	11.0
	175	26,520 ¹⁾	25,190 ¹⁾	152	144	11.0

The luminaires are available with other optics, light colours, control functions and light management. (see 'Technical properties')

¹⁾ Factory settings

POLE-TOP BRACKETS

The following items are available for mounting our technical outdoor lights from the 42, 46, 47 and 48 series on walls, building corners or on poles. Painting in RAL or DB colours is possible at an extra charge.

Cast Aluminium Pole Arm Carrier

with separate bracket tube/support spigot \varnothing 42mm or \varnothing 60mm, unpainted

Type	D	L	Weight [kg]
4861	60	100	1.7
4864	60	250	2.5

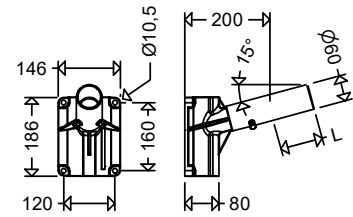

Welded Aluminium Pole Arm Carrier

with welded bracket tube/support spigot \varnothing 42 mm or \varnothing 60 mm, powder-coated RAL 7035 (light grey) or DB702 (micaceous iron ore)

Type	D	L	Weight [kg]
4871	60	100	0.7
4871 DB702	60	100	0.7

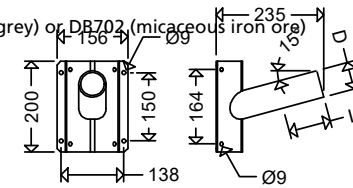

Pole-top brackets

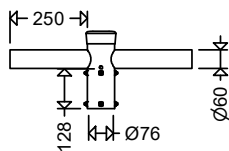
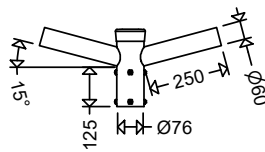

Pole-top brackets \varnothing 60 mm

Type	Description	Weight [kg]	for following light fittings:
MAU 601/1	for 1 fitting	3.7	42, 46, 47, 48, 51, 52
MAU 601/2	for 1 fitting	5.1	
MAU 601/3	for 3 fittings	6.5	
MAU 601/4	for 4 fittings	7.9	

Pole-top brackets \varnothing 60 mm

Type	Description	Weight [kg]	for following light fittings:
MAU 610/1	for 1 fitting	3.7	42, 46, 47, 48, 51, 52
MAU 610/2	for 1 fitting	5.1	
MAU 610/3	for 3 fittings	6.5	
MAU 610/4	for 4 fittings	7.9	



CAMINO

SERIES 47 / 48



Anyone using them for the first time will rave about their installation and maintenance-friendly design. No awkward handling in tight connection spaces, no 'overhead work' and no additional pole flanges or adapter pieces. Above all, however, the separation of the upper and lower sections

during assembly makes installation extremely quick and easy. However, ease of installation and maintenance are by no means all that the series has to offer. Long service life, high efficiency, outstanding quality and maximum flexibility thanks to the VARIO and VARIO NFC ver-

sions as well as the versions with the LIMAS Air SYNC and RFL light management systems round off the overall package. With its clear and modern design language, the 47 / 48 series is the perfect solution for your lighting tasks in public spaces.



Advantages

- Durable, corrosion-resistant die-cast aluminium housing with smooth surface without cooling fins
- Excellent thermal management due to direct adaption of the LED modules to the housing
- Integrated pressure compensation system prevents condensation in the interior
- Universal pole mounting system, foldable without tools, for post top or side entry mounting
- No additional mast flanges or adapter pieces required
- Removable upper part of the housing allows a comfortable, time- and cost-saving mounting in 2 steps:
1st step: Mount bottom part on the pole and connect the mains
2nd step: Hinge upper part, connect isolating plug and shut the housing. READY
- Adjustable inclination of the light fitting, no tools required
- Upgrades or converts in regards to technical development by easy change of the upper part of the housing. After the change of the LED-modules the upper part of the housing can be used again
- Homogeneous illumination due to the Multi-Layer-Technology
- Eco-friendly, no light emission into the upper half-space, ULOR = 0
- Versions dimmable to 10 % and with color temperature up to 3,000 K comply with Dark Sky requirements
- Sustainable, control gear and LED-module replaceable by qualified personnel on-site
- Future proof by using standardised LED modules (Zhaga)
- GreenLine luminaire, outstanding sustainable design

Main uses

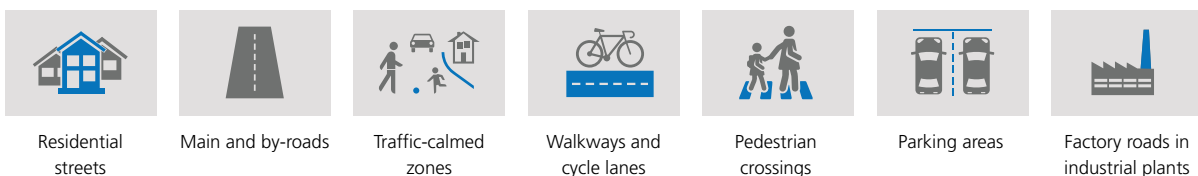

2-part housing made of die-cast aluminium, smooth surface without cooling fins, powder-coated DB 702 (mica-iron), upper section can be folded down and removed

Silicone seals between the upper and lower part and between the upper part and glass cover ensure protection class IP66

ECG high-quality and durable with high surge voltage resistance of 10 kV

DIP switch on VARIO version for setting the luminous flux without tools

Isolating plug for disconnecting the light from the power supply without tools

Cable entry with strain relief

Pressure equalisation system to prevent condensation in the interior

Tilt angle adjustment for top mounting 0°, 5° and 10°, for bracket mounting 0°, -5°, -10° and -15° depending on the tilt of the cantilever arm

Universal pole mounting system, can be folded down onto the mast base or mast top without tools, for all standard mast braid diameters (mast base Ø 60 mm, mast top Ø 60 and 76 mm), separate reduction accessories are required for mast base mounting Ø 42 mm

Optics highly efficient lens optics for optimum light beam

LED module highly efficient, long-lasting high-power LED modules. Zhaga conformity ensures long-term availability of standardised replacement modules

Cover plate painted white, with double effect. Prevents the inside of the housing from being seen (aesthetic aspect) and increases the lumen output of the luminaire (efficiency aspect)

Cover flat safety glass, impact resistance IK 09



Video:
Assembly and
component
replacement



PEDESTRIAN CROSSING LIGHTING

Special requirements are placed on the standard-compliant lighting of pedestrian crossings, which are specified in DIN 67523. To increase the safety of pedestrians and drivers at these critical zones in road traffic, a clear contrast must be created between the pedestrian crossing lighting and the rest of the lane lighting. FUE optics with special light distribution are available for this purpose. This asymmetrical light distribution at an angle to the longitudinal axis of the luminaire with limited rearward emission, combined with high vertical and

horizontal illuminance, means that a pedestrian is clearly visible to drivers even from a great distance. It is also recommended to use a different light colour for pedestrian crossing lighting so that it stands out clearly from the street lighting and thus has an additional signalling effect. Light colour 722, which comes closest to a high-pressure sodium lamp with its yellowish colour impression, is particularly suitable for this if the surrounding street lighting is equipped with a neutral white light colour.

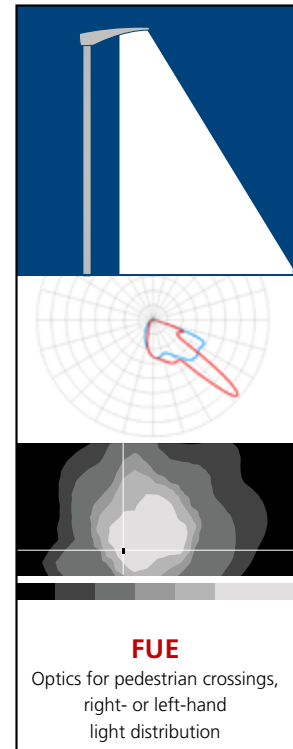
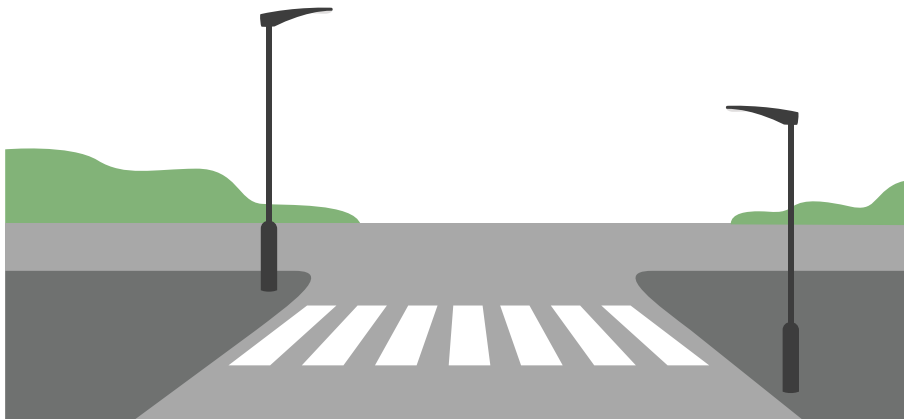



INSTALLATION MADE EASY

The separation of the upper and lower housing sections makes installation extremely simple, time and cost-saving.

- Open the light, disconnect the plug and remove the upper section.
- Mount lower section on pole and connect electrically.
- Hook in the upper section, connect the isolating plug, close and screw in place - DONE.





A SPECIAL KIND OF ENDURANCE TEST

Those who master thermal management have the service life under control

Who hasn't seen them, the 'palm islands' piled up in the sea off Dubai? They are a fascinating sight from an aeroplane. An ideal place to put the Streetlight 47 to a special endurance test. Series 47 luminaires were installed on the coastal strip in front of the large palm tree in the summer months of 2013 to test the effectiveness of thermal management under extreme environmental conditions.

Equipped with data loggers to monitor the current and temperature values, the lights were tested under the toughest possible conditions:

- Highest LED assembly (Type 47 6403)
- Highest current (700 mA)
- Operation at outdoor temperatures up to +50 °C and in direct sunlight

The evaluation of the data produced absolutely impressive results. The luminaires operated within the permissible temperature range at all times without the current flowing through the integrated over-temperature protection, which protects the LED board and ECG from excessive temperatures.

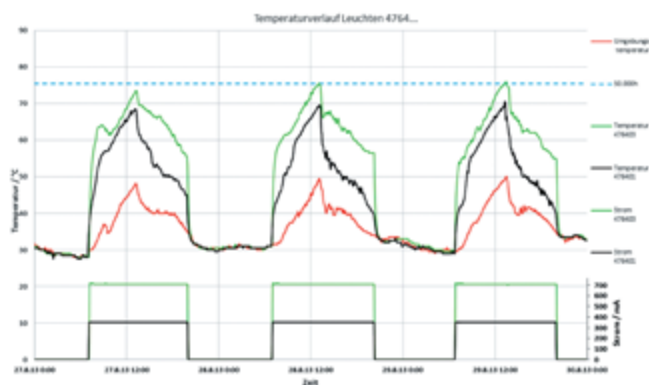

As a result, the light's specified service life is demonstrably maintained even at the maximum permissible temperatures, and the 47 has additional service life reserves when used in temperate Central European latitudes with significantly lower temperatures.

TECHNICAL PROPERTIES

Series 47 CAMINO

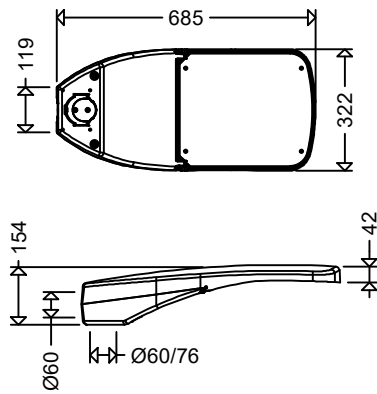

Series 48 CAMINO

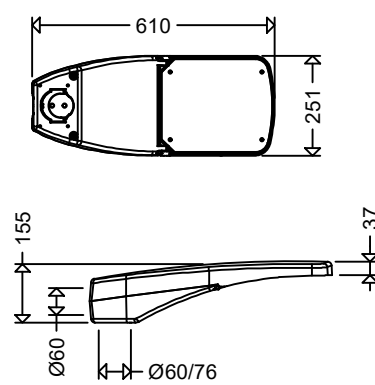

i All light fittings also available with connected cable (H07RN-F or NYM) in the required length.

	48 CAMINO	47 CAMINO
Recommended mounting height	4 - 10 m	7 - 12 m
Wind-exposed surface	0.05 m ²	
Luminous flux (LF 740)	1,510 - 11,140 lm	6,020 - 22,030 lm
Luminous flux (LF 740)VARIO / NFC	1,330 - 11,140 lm	2,760 - 22,030 lm
Luminous flux (LF 730)	1,430 - 10,580 lm	5,720 - 20,930 lm
Luminous flux (LF 730) VARIO / NFC	1,260 - 10,580 lm	2,620 - 20,930 lm
Connected load	9 - 70 W	34 - 140 W
Connected load VARIO / NFC	9 - 70 W	16 - 140 W
Luminous efficiency (LF 740)	157 - 175 lm/W	157 - 177 lm/W
Luminous efficiency (LF 740) VARIO / NFC	148 - 167 lm/W	150 - 168 lm/W
Luminous efficiency (LF 730)	149 - 166 lm/W	150 - 168 lm/W
Luminous efficiency (LF 730) VARIO / NFC	140 - 159 lm/W	151 - 171 lm/W
Optics	AB, ABL, RWX, RNX, A	... + FUE
Light colours	740, 730, 722 518	
Control functions	LR, LA, CL, DIMD, EcoTune	LR, LA, CL, DIMD, EcoTune
Light management	LIMAS Air SYNC, RFL	LIMAS Air SYNC, RFL
Variable luminous flux setting	VARIO / NFC	VARIO / NFC
IP rating	IP66	
Protection class (standard/option)	II / I	
ECG	220 - 240 V, 50 - 60 Hz	
IK rating	10 kV	
LED module	Highpower, Zhaga compliant	
Service life	L90 > 100,000 h at max. temperature	
Energy efficiency class	B	

Options:

Seawater-resistant version, bird deterrence, backside light shielding, for connection to a central power supply system, for lighting locks and waterways, for property protection (fence and apron lighting), track and platform lighting (DB listing), special painting in RAL colours

MAXIMUM EFFICIENCY OR LOWEST INVESTMENT COSTS

When solving your lighting task, you often have the choice between maximum energy efficiency and the lowest initial investment. Compare and choose the optimum solution for your project.

The standard versions of the series are listed in the table. Customised lumen packages can be programmed at the factory.

Standard types

asymmetrical wide distribution

Type	Connected load [W]	Luminous flux [lm]		Luminous efficiency [lm/W]		Weight [kg]
		LF 740	LF 730	LF 740	LF 730	
48 0801	9	1,510	1,430	168	159	7.0
48 0802	13	2,100	2,000	162	154	7.0
48 0803	18	2,840	2,700	158	150	7.0
48 1601	17	2,900	2,760	171	162	7.0
48 1602	25	4,050	3,850	162	154	7.0
48 1603	35	5,480	5,210	157	149	7.0
48 2401	26	4,470	4,250	172	163	7.1
48 2402	37	6,210	5,900	168	159	7.1
48 2403	53	8,340	7,920	157	149	7.4
48 3201	34	5,940	5,640	175	166	7.5
48 3202	50	8,280	7,870	166	157	7.5
48 3203	70	11,140	10,580	159	151	7.5
48 L50 VARIO / NFC	9	1,330	1,260	148	140	7.5
	15	2,510	2,380	167	159	7.5
	18	3,090 ¹⁾	2,940	172	163	7.5
	35	5,480	5,210	157	149	7.5
48 L100 VARIO/ NFC	16	2,730	2,590	171	162	7.6
	38	6,730	6,390	177	168	7.6
	54	9,020 ¹⁾	8,570	167	159	7.6
	70	11,140	10,580	159	151	7.6

Type	Connected load [W]	Luminous flux [lm]		Luminous efficiency [lm/W]		Weight [kg]
		LF 740	LF 730	LF 740	LF 730	
47 3201	34	6,020	5,720	177	168	10.2
47 3202	50	8,400	7,980	168	160	10.2
47 3203	70	11,360	10,790	162	154	10.2
47 4801	52	8,980	8,530	173	164	10.2
47 4802	75	12,500	11,880	167	158	10.2
47 4803	106	16,850	16,010	159	151	10.2
47 6401	69	11,850	11,260	172	163	10.3
47 6402	99	16,440	15,620	166	158	10.3
47 6403	140	22,030	20,930	157	150	10.3
47 L100 VARIO/ NFC	16	2,760	2,620	173	164	10.2
	38	6,830	6,490	180	171	10.2
	54	9,160 ¹⁾	8,700	170	161	10.2
	70	11,360	10,790	162	154	10.2
47 L150 VARIO/ NFC	24	4,130	3,920	172	163	10.2
	45	7,780	7,390	173	164	10.2
	82	13,620 ¹⁾	12,940	166	158	10.2
	106	16,850	16,010	159	151	10.2
47 L210 VARIO/ NFC	32	5,460	5,190	171	162	10.3
	79	13,390	12,720	169	161	10.3
	99	16,440 ¹⁾	15,620	166	158	10.3
	140	22,030	20,930	157	150	10.3

The luminaires are available with other optics, light colours, control functions and light management. (see 'Technical properties')

¹⁾ Factory settings



FILOS VARIO

SERIES 42 VARIO

Compact in size, modern in design and equipped with all the advantages of the VARIO concept, the FILOS VARIO is an attractive solution for illuminating roads and cycle paths.

Thanks to the option of variably adjusting the luminous flux via a DIP switch or a

smartphone app, the luminaire covers a wide range of applications, for which several different luminaire types are usually required.

For the housing, you have the choice between die-cast aluminium or the cheaper version in glass fibre-reinforced polyester with a protective coating. Both versions are

of high quality and durable. The FILOS VARIO impresses across the board with its ease of installation. The universal pole mounting system, tool-free opening centre lock and tool-free replacement of the gear tray leave nothing to be desired.





Advantages

- Simple, fast, tool-free setting of the luminous flux on site, by means of integrated switch or smartphone app
- Reduction in the variety of types, a single type replaces several types
- Plain surfaces of the housing, no dirt deposits
- PC cover with high impact resistance IK10
- Tool-free opening of the luminaire (central toggle clamp)
- Tiltable universal pole mounting system for pole-top and side-entry mounting, no tools required
- Removable multi-function cable entry enables pre-assembly of the connection cable
- Tool-free exchangeable gear tray
- Protection of the LED against mechanical and electrostatic damage due to sandwich design of cover and gear tray
- Service life L90 > 100,000 hours
- Highly efficient up to 162 lm/W
- EVG with high surge voltage resistance 10 kV
- Homogeneous illumination due to the Multi-Layer-Technology
- Eco-friendly, ULOR = 0 %
- Sustainable, control gear and LED-module replaceable by qualified personnel on-site
- Future proof by using standardized LED-modules (Zhaga) and long-term availability of spare parts

Main uses

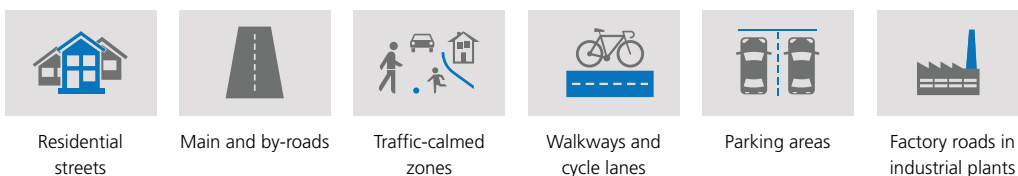

Housing optionally available in die-cast aluminium or glass fibre reinforced polyester

Centre lock stainless steel, can be opened without tools



Multifunctional cable entry removable for pre-assembly of the connection cable

Isolating plug for tool-free disconnection of the device carrier from the power supply

Universal pole mounting system can be folded down without tools onto the mast base or mast top, for all standard mast braid diameters (mast base 42 and 60 mm, mast top 60 and 76 mm), no additional mast flanges or adapters required. Always fits.

Tilt angle adjustment for attachment mounting 0°, -5°, -10°, -15° depending on the tilt of the cantilever arm

ECG high-quality and durable with high surge voltage resistance 10 kV

DIP switch for setting the luminous flux without tools

LED module with optics, Zhaga conformity of the modules ensures long-term availability of standardised modules for later replacement requirements

Gear tray painted white snapped into the cover to protect the LED from mechanical and electrostatic damage (sandwich design). Detachable for easy component replacement

Cover UV-stabilised polycarbonate, impact resistance IK10, tiltable and detachable



Video:
Mounting and tool-free adjustment of the luminous flux



LUMINOUS FLUX SETTING

With the VARIO version, the luminous flux is set manually using the DIP switch on the ECG. The switch settings for the most common comparable conventional versions are noted on the sticker. For example, the 42 L50 VARIO in light colour 740 is factory-set to a luminous flux of approx. 3,250 lm, which corresponds approximately to a conventional HME 125 W or HST 70 W version.

42AL L50 VARIO			
W	lm	lm/W	Substitute for ca.
9	1,400	156	HME 50, HST 35
15	2,640	176	HME 80, HST 50
18	3,250	181	HME 125, HST 70
35	5,670	162	2x HST 70



With the VARIO NFC version, the luminous flux is set using a smartphone app. The link to the app can be found in the installation instructions.

COMPONENT REPLACEMENT

The FILOS VARIO is opened using the central lock on the front and disconnected from the power supply by pulling the isolating plug. The complete device carrier with cover glass can then be removed and replaced. All without tools, simply and quickly.

The cover glass, into which the reflector with ECG and LED module is snapped (sandwich design), protects the sensitive LEDs from electrostatic or mechanical damage.



GLASS FIBRE REINFORCED POLYESTER HOUSING - AN ALTERNATIVE?

Die-cast aluminium or glass fibre-reinforced polyester - both materials have their advantages. Whereas GRP housings were largely standard in the days of conventional technology, aluminium housings have become established with the advent of LED technology. Primarily to dissipate the heat generated by the LEDs. With low-power luminaires and the enormous increase in LED efficiency, this is no longer a decisive argument. The luminaire can be painted in DB 702 or RAL 7035 to prevent the housing from being visually impaired by weathering.

Advantages

- Low weight
- Durable with very good mechanical properties
- Good electrical properties (high insulation resistance, high dielectric strength)
- High temperature and UV resistance



TECHNICAL PROPERTIES

Series 42 FILOS VARIO

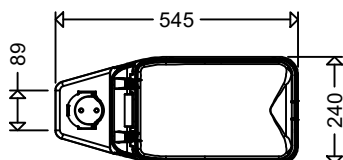
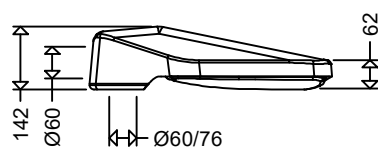

i All light fittings also available with connected cable (H07RN-F or NYM) in the required length.

	42 FILOS VARIO
Recommended mounting height	3 - 6 m
Wind-exposed surface	0,06 m ²
Luminous flux (LF 740)	1,400 - 11,130 lm
Luminous flux (LF 730)	1,330 - 10,570 lm
Connected load	9 - 50 W
Luminous efficiency (LF 740)	156 - 181 lm/W
Luminous efficiency (LF 730)	148 - 172 lm/W
Optics	AB, ABL, RWX, RNX, A
Light colours	740, 730, 722 518
Control functions	LR, LA, CL, DIMD
Light management	LIMAS Air SYNC, RFL
Variable luminous flux setting	VARIO / NFC
IP rating	IP66
Protection class (standard/option)	II / I
ECG	220 - 240 V, 50 - 60 Hz
IK rating	10 kV
LED module	Highpower, Zhaga compliant
Service life	L90 > 100,000 h
Energy efficiency class	B

Options:

Housing made of glass fibre-reinforced polyester, seawater-resistant version, bird deterrence, backside light shielding, for connection to a central power supply system, special painting in RAL colours

STANDARD TYPES

The standard versions of the series are listed in the table. Customised lumen packages can be programmed at the factory.

Type	Connected load [W]	Luminous flux [lm]		Luminous efficiency [lm/W]		Weight [kg]
		LF 740	LF 730	LF 740	LF 730	
42AL L50 VARIO	9	1,400	1,330	156	148	4.9
	15	2,640	2,510	176	167	4.9
	18	3,250 ¹⁾	3,090	181	172	4.9
	35	5,670	5,390	162	154	4.9
42AL L100 VARIO	16	2,820	2,680	176	168	4.9
	20	6,850	6,510	180	171	4.9
	38	9,080	8,630	168	160	4.9
	50	11,130 ¹⁾	10,570 ¹⁾	159	151	4.9
42 L50 VARIO	9	1,400	1,330	156	148	4.0
	15	2,640	2,510	176	167	4.0
	18	3,250	3,090	181	172	4.0
	35	5,670 ¹⁾	5,390	162	154	4.0
42 L100 VARIO	16	2,820	2,680	176	168	4.1
	20	6,850	6,510	180	171	4.1
	38	9,080	8,630	168	160	4.1
	50	11,130 ¹⁾	10,570 ¹⁾	159	151	4.1
42 L50 VARIO DB702	9	1,400	1,330	156	148	4.0
	15	2,640	2,510	176	167	4.0
	18	3,250 ¹⁾	3,090	181	172	4.0
	35	5,670	5,390	162	154	4.1
42 L100 VARIO DB702	16	2,820	2,680	176	168	4.1
	20	6,850	6,510	180	171	4.1
	38	9,080	8,630	168	160	4.1
	50	11,130 ¹⁾	10,570 ¹⁾	159	151	4.1

The luminaires are available with other optics, light colours, control functions and light management.
(see 'Technical properties')

¹⁾ Factory settings



LUCA

SERIES 46 G2 VARIO

With its classic shape, the high-quality light fitting series 46 have an impressively user-friendly design. Assembly, maintenance and component replacement all take place with practically no tools at all thanks to the universal pole mounting system, central locking system and compact unit consisting of

the electric block and cover. With their UV-stabilized PC cover and obligatory varnishing - even for the version with polyester housing - the light fittings cut a fine figure in all usage scenarios. The use of the LIMAS Air SYNC light management system and the RFL versions with Zhaga-compliant

sockets for the subsequent connection of light management components can also be realised with the 46. An ultra-modern solution in a classic box luminaire design.



Advantages

- Reduction in the variety of types thanks to variably adjustable luminous flux
- simple, fast, tool-free setting of the luminous flux on site, by means of integrated switch, can be changed at any time
- High flexibility due to almost infinitely variable luminous flux setting
- Long-life housing polyester housing with UV and weather-resistant protective coating
- Protection of the LEDs against mechanical and electrostatic discharge due to sandwich-design of gear tray and cover
- Integrated pressure compensation system for defined 'breathing' of the luminaire prevents condensation in the interior
- Universal mast mounting system that can be folded down for attachment or top mounting without tools
- No additional adapters or mast flanges required
- Compact unit consisting of glass, device carrier and LED that can be opened, folded down and unhooked without tools, enabling convenient maintenance and quick component replacement or retrofitting in the event of technical developments
- Homogeneous illumination due to the Multi-Layer-Technology
- Sustainable, control gear and LED-module replaceable by qualified personnel on-site
- Future proof by using standardised LED modules (Zhaga)

Main uses

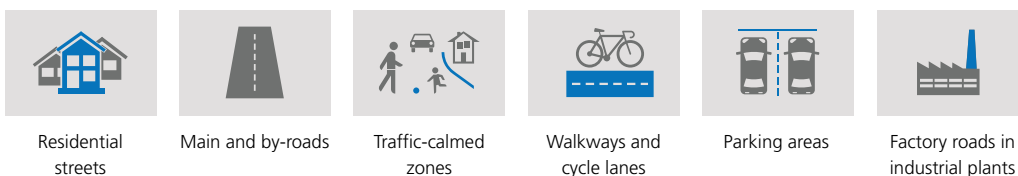



Robust housing made of glass fibre-reinforced polyester with durable UV and weather-resistant protective coating

Centre lock made from corrosion-resistant stainless steel

Multifunctional cable entry removable for pre-assembly of the connection cable

Isolating plug for tool-free disconnection of the light from the power supply

Integrated pressure equalisation system for defined breathing of the luminaire prevents condensation inside the luminaire

Universal pole mounting system, can be folded down onto the mast base or mast top without tools, for all standard mast braid diameters (mast base Ø 60 mm, mast top Ø 60 and 76 mm), separate reduction accessories are required for mast base mounting Ø 42 mm

Closed sealing system of connection and equipment compartment with UV-resistant profile seal (one-room sealing)

High-quality and durable ECG with high surge voltage resistance of 10 kV

DIP switch for setting the luminous flux without tools

Gear tray made of aluminium as a compact unit with ECG and LED module connected to the aluminium frame in a non-contact manner (sandwich design), compact unit can be folded down and removed without tools

Cover plate/device mount painted white, prevents the inside of the housing from being seen (aesthetic aspect) and increases the lumen output of the luminaire (efficiency aspect)

Highly efficient, durable high-power LED modules. Zhaga conformity ensures long-term availability of standardised modules for future replacement requirements

Highly efficient lens optics for optimum light beam

Flat cover made of temperature-resistant PC

THE 'TOOL-FREE CONCEPT'

Time costs money!

Simple, quick installation and tool-free maintenance and conversion are therefore a great advantage. The 46 is fitted and connected in just a few simple steps. And largely without tools.

- The universal pole mounting system can be folded down onto the pole base or pole top without tools.
- The light can be opened without tools using the central lock.
- The multifunctional cable entry can be removed and reinserted without tools, allowing the connection cable to be conveniently pre-assembled outside the luminaire.
- The electrical connection and disconnection from the power supply is carried out without tools using the isolating plug
- The compact unit consisting of aluminium frame, gear tray and PMMA cover can be removed without tools. This enables the LED system to be replaced quickly in the event of a fault or when upgrading to a new, more efficient system at the end of its service life.



TECHNICAL PROPERTIES

Series 46 G2 LUCA VARIO

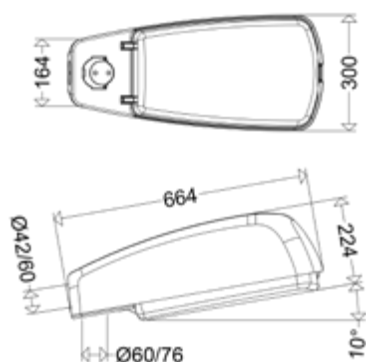

i

All light fittings also available with connected cable (H07RN-F or NYM) in the required length.

	46 G2 LUCA VARIO
Recommended mounting height	4 - 6 m
Wind-exposed surface	0.11 m ²
Luminous flux (LF 740)	1,420 - 11,720 lm
Luminous flux (LF 730)	1,350 - 11,130 lm
Connected load	9 - 70 W
Luminous efficiency (LF 740)	158 - 188 lm/W
Luminous efficiency (LF 730)	150 - 178 lm/W
Optics	AB, ABL, RWX, RNX, A
Light colours	740, 730, 722, 518
Control functions	LR, LA, CL, DIMD
Light management	LIMAS Air SYNC, RFL
Variable luminous flux setting	VARIO / NFC
IP rating	IP65
Protection class (standard/option)	II / I
ECG	220 - 240 V, 50 - 60 Hz
IK rating	10 kV
LED module	Zhaga compliant
Service life	L90 > 100,000 h
Energy efficiency class	B

Options:

Seawater-resistant version, backside light shielding, for connection to a central power supply system, aluminium housing, special painting in RAL colours

MAXIMUM EFFICIENCY OR LOWEST INVESTMENT COSTS

When solving your lighting task, you often have the choice between maximum energy efficiency and the lowest initial investment. Compare and choose the optimum solution for your project.

The standard versions of the series are listed in the table. Customised lumen packages can be programmed at the factory.

Standard types

Type	Connected load [W]	Luminous flux [lm]		Luminous efficiency [lm/W]		Weight [kg]
		LF 740	LF 730	LF 740	LF 730	
46 L50 G2 VARIO	9	1,420	1,350	158	150	5.9
	15	2,690	2,560	179	172	5.9
	18	3,310 ¹⁾	3,140	184	174	5.9
	35	5,840	5,550	167	159	5.9
46 L100 G2 VARIO	16	2,910	2,760	182	173	6.0
	38	7,130	6,770	188	178	6.0
	54	9,510 ¹⁾	9,030	176	167	6.0
	70	11,720	11,130	167	159	6.0

¹⁾ Factory settings





PENDO

SERIES 49 / 59

Rope-supported light fittings must meet completely different requirements. Since they hang right above the street, maintenance and repair work can greatly restrict traffic or even block roads. This means that speed is of the essence. Here, series 49 / 59 are utterly convincing. The toolless mechanical and electrical separation of the housing from the upper part with the bracket takes place in just seconds - and the traffic

can flow freely again. Use of a complete replacement housing means that a second visit is not required. Component replacement can be performed comfortably in the workshop and afterwards the replaced housing is ready-for-use again. Furthermore, series 59 offers top flexibility. The unique stainless steel bracket is rotatable on all sides and can be tilted up to 15°. With its preformed connection box, it enables the universal use of

the rope-supported light fittings on lengthwise, crosswise and inclined ropes - with the corresponding accessories - even on 3-point rope supports. The design has been thought out in detail and makes these light fittings really attractive.





Advantages

- Plain surface of the housing without cooling fins, no dirt deposits
- Flat safety glass with high impact resistance IK10
- ECG with high surge voltage resistance 10 kV
- Excellent thermal management due to direct adaption of the LED-modules to the housing
- Service life L90 > 100,000 hours
- Integrated pressure compensation system prevents condensation in the interior
- Homogeneous illumination due to the Multi-Layer-Technology
- Time and cost-saving assembly thanks to separation of upper and lower housing sections
- Quick component replacement thanks to tool-free removable lower housing section
- Universal use on transverse and longitudinal ropes, inclined ropes or 3-point ropes
- Eco-friendly, no light emission into the upper half-space, ULOR = 0
- Versions dimmable to 10 % and with color temperature up to 3,000 K comply with Dark Sky requirements
- Sustainable, control gear and LED-module replaceable by qualified personnel on-site
- Future proof by using standardised LED modules (Zhaga)
- GreenLine luminaire, outstanding sustainable design

Main uses



Residential streets



Main and by-roads

Stainless steel carrying handle, rotatable through 360° on all sides and tiltable by 15°

Ball joint swivel mechanism enables universal use on transverse, longitudinal and inclined ropes

Clamp fastening for suspension cables with a diameter of 6–12 mm

Two-piece die-cast aluminium housing, smooth surface without cooling fins, powder-coated DB 702 (mica-iron). Lower section can be tilted down without tools and detached from the upper section.

Pressure equalisation system to prevent condensation in the interior

Connection box with isolating plug for tool-free disconnection of the luminaire from the power supply

Cable entry

Stainless steel bracket for opening the luminaire without tools

LED module highly efficient, long-life high-power LED. Zhaga conformity ensures long-term availability of standardised modules for later replacement requirements

Cover plate painted white, with double effect. Prevents the inside of the housing from being seen (aesthetic aspect) and increases the lumen output of the luminaire (efficiency aspect)

Flat safety glass with high impact resistance IK10

Optics highly efficient lens optics for optimum light beam

ECG high-quality and durable with high surge voltage resistance of 10 kV



Video:
Assembly and
component
replacement

INSTALLATION AND MAINTENANCE MADE SIMPLE



The lower part of the housing can be removed without tools, making installation extremely easy, time and cost-saving.

- Open the stainless steel bracket and separate the upper section from the lower section
- Hook the upper section with the carrying handle into the cable and connect electrically
- Hook in the lower section, connect the isolating plug, close and lock - DONE!

Repair work and any necessary component replacement can also be carried out quickly without disrupting traffic for any length of time. All you need to do is separate the lower part of the housing from the upper part and remove it. There is no need for time-consuming dismantling of the complete luminaire from the cable or strenuous "overhead work" on the suspended luminaire. All components such as ECG, LED and optics are contained in the lower part of the housing. The defective component can then be replaced on site or conveniently in the workshop. If the component is to be replaced in the workshop, a second journey to the installation site can be omitted by installing a complete replacement housing. Once the defective component has been replaced, the housing is ready for use again.

3-POINT SUSPENSION

To attach the light to 3 cables, the support bracket is replaced by the 3-point suspension. The ball-and-socket swivel mechanism and therefore the universal application options are retained without restriction.



TECHNICAL PROPERTIES

Series PENDO 59

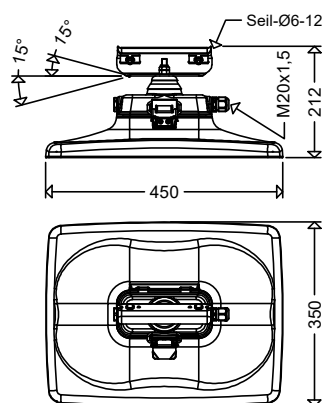

Series PENDO 49

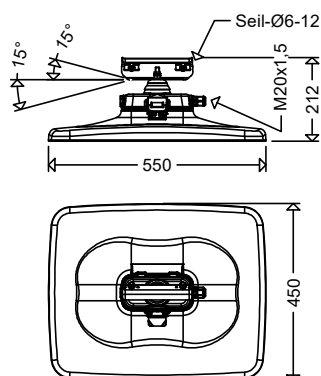

i

All light fittings also available with connected cable (H07RN-F or NYM) in the required length.

	59 PENDO	49 PENDO
Recommended mounting height	6 - 9 m	7 - 10 m
Wind-exposed surface	0,04 m ²	0,05 m ²
Luminous flux (LF 740)	3,210 - 12,080 lm	12,580 - 23,570 lm
Luminous flux (LF 740) VARIO	1,470 - 12,080 lm	5,790 - 23,570 lm
Luminous flux (LF 730)	3,050 - 11,480 lm	11,950 - 22,390 lm
Luminous flux (LF 730) VARIO	1,400 - 11,480 lm	5,500 - 22,390 lm
Connected load	17 - 70 W	69 - 140 W
Connected load VARIO / NFC	9 – 70 W	32 - 140 W
Luminous efficiency (LF 740)	173 - 189 lm/W	168 - 182 lm/W
Luminous efficiency (LF 740) VARIO	163 - 191 lm/W	168 - 181 lm/W
Luminous efficiency (LF 730)	164 - 179 lm/W	160 - 173 lm/W
Luminous efficiency (LF 730) VARIO	156 - 182 lm/W	160 - 172 lm/W
Optics	SB	
Light colours	740, 730, 722, 518	
Control functions	LR, LA, CL, DIMD	... + EcoTune
Light management	LIMAS Air SYNC, RFL	
Variable luminous flux setting	VARIO	
IP rating	IP66	
Protection class (standard/option)	I / II	
ECG	220 - 240 V, 50 - 60 Hz	
Overvoltage protection	10 kV	
LED module	Highpower, Zhaga compliant	
Service life	L90 > 100,000 h	
Energy efficiency class	B	

Options:

Seawater-resistant version, special painting in RAL colours

MAXIMUM EFFICIENCY OR LOWEST INVESTMENT COSTS

When solving your lighting task, you often have the choice between maximum energy efficiency and the lowest initial investment. Compare and choose the optimum solution for your project.

The standard versions of the series are listed in the table. Customised lumen packages can be programmed at the factory.

Standard types

Type	Connected load [W]	Luminous flux [lm]		Luminous efficiency [lm/W]		Weight [kg]
		LF 740	LF 730	LF 740	LF 730	
59 1601	17	3,210	3,050	189	179	6.6
59 1602	25	4,480	4,260	179	170	6.6
59 1603	35	6,070	5,770	173	165	6.6
59 3201	34	6,420	6,100	189	179	7.0
59 3202	50	8,950	8,500	179	170	7.0
59 3203	70	12,080	11,480	173	164	7.0
59 L50 VARIO	9	1,470	1,400	163	156	6.6
	15	2,780	2,640	185	176	6.6
	18	3,420 ¹⁾	3,250	190	181	6.6
	35	6,070	5,770	173	165	6.6
59 L100 VARIO	16	2,950	2,800	184	175	7.0
	38	7,270	6,910	191	182	7.0
	54	9,760 ¹⁾	9,270	181	172	7.0
	70	12,080	11,480	173	164	7.0

Type	Connected load [W]	Luminous flux [lm]		Luminous efficiency [lm/W]		Weight [kg]
		LF 740	LF 730	LF 740	LF 730	
49 6401	69	12,580	11,950	182	173	11.8
49 6402	99	17,520	16,640	177	168	11.8
49 6403	140	23,570	22,390	168	160	11.8
49 L210 VARIO	32	5,790	5,500	181	172	11.8
	79	14,250	13,540	180	171	11.8
	99	17,520	16,640	177	168	11.8
	140	23,570 ¹⁾	22,390	168	160	11.8

The luminaires are available with other optics, light colours, control functions and light management. (see "Technical features")

¹⁾ Factory settings





REDONDO

SERIES 55



The requirements for cable luminaires are very specialised. Suspended in the middle of the road, maintenance and repair work can quickly lead to considerable disruption to traffic and even full road closures. Speed is therefore of the essence during such work. And it is precisely this trump card that our 55 series plays! In addition to opening the luminaires without tools, components can also be replaced completely without tools:

The LED module(s) and ECG are each mounted on a carrier plate, which can be removed quickly and easily after disconnecting the isolating plugs. Connection is also a breeze thanks to the FastConnect quick connector. An absolute added value in flowing traffic. The stainless steel support bracket, which can be rotated on all sides and tilted by up to 15°, enables universal use of the rope lights on transverse or longitudinal ro-

pes, inclined ropes and - with the appropriate accessories - also on 3-point span ropes. A design that has been thought through down to the last detail, making these lights highly attractive.



Advantages

- Plain surface of the housing without cooling fins, no dirt deposits
- Flat safety glass with high impact resistance IK09
- EVG with high surge voltage resistance 10 kV
- Service life L90 > 100,000 hours
- Integrated pressure compensation system prevents condensation in the interior
- Homogeneous illumination due to the Multi-Layer-Technology
- Fast mains connection thanks to integrated FastConnect quick connection plug
- Tool-free ECG and LED module replacement
- Universal usage on cross- and longitudinal ropes, inclined ropes or 3-point rope supports (see accessories) due to all-side rotatable and up to 15° inclinable stainless steel bracket
- Eco-friendly, no light emission into the upper half-space, ULOR = 0
- Versions dimmable to 10 % and with color temperature up to 3,000 K comply with Dark Sky requirements
- Sustainable, control gear and LED-module replaceable by qualified personnel on-site
- Future proof by using standardized LED-modules (Zhaga) and long-term availability of spare parts
- GreenLine luminaire, outstanding sustainable design

Main uses



Residential streets



main and by-roads

Integrated FastConnect quick connector

Stainless steel carrying handle, rotatable through 360° on all sides and tiltable by 15°

Ball joint swivel mechanism enables universal use on transverse, longitudinal and inclined ropes

Clamp fastening for suspension cables with a diameter of 6–12 mm

Die-cast aluminium housing, painted DB 702 (mica-iron)

Second introduction for through-hole wiring

Pressure equalisation system to prevent condensation in the interior

Die-cast aluminium bracket for opening the luminaire without tools

LED module highly efficient, long-life high-power LED. Zhaga conformity ensures long-term availability of standardised modules for later replacement requirements

Cover plate painted white, with double effect. Prevents the inside of the housing from being seen (aesthetic aspect) and increases the lumen output of the luminaire (efficiency aspect)

Flat safety glass, hinged, foldable with high impact resistance IK09

Optics highly efficient lens optics for optimum light beam

ECG high-quality and durable with high surge voltage resistance of 10 kV



Video:
Assembly and
component
replacement

TOOL-FREE COMPONENT EXCHANGE

The REDONDO impresses with both its elegant design and its maximum ease of maintenance. Thanks to its unique design, components can be replaced without tools in seconds – maximum speed, minimum disruption!

- disconnect the FastConnect quick connection plug.
- open the luminaire without tools using the two toggle levers
- comfortable folding down of the luminaire cover
- release and fold down the device carrier without tools
- Disconnect the plug connection
- release and fold down the device carrier without tools
- easy removal and replacement of LED carriers

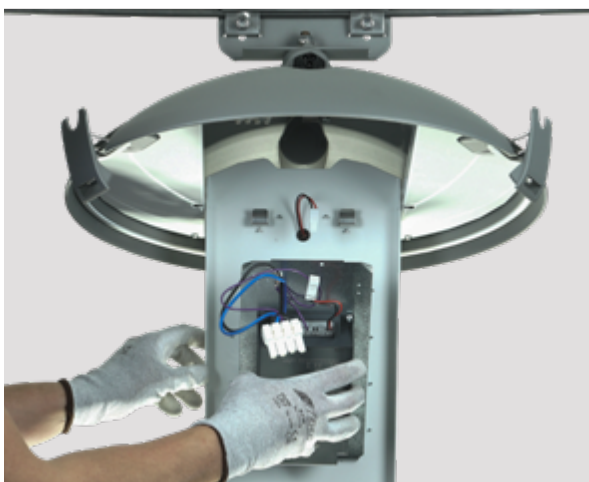
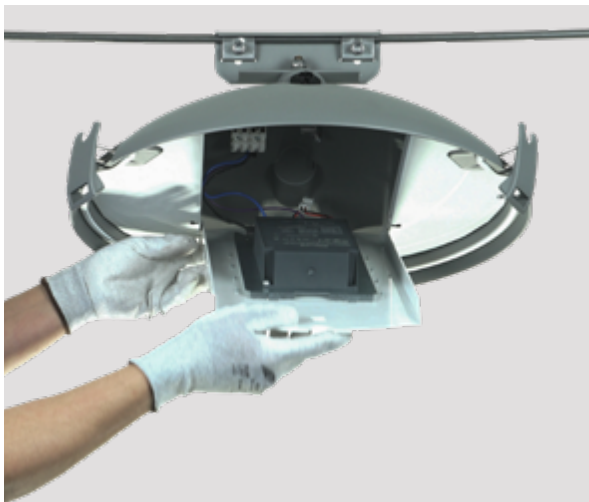

TECHNICAL PROPERTIES

Series 55 REDONDO

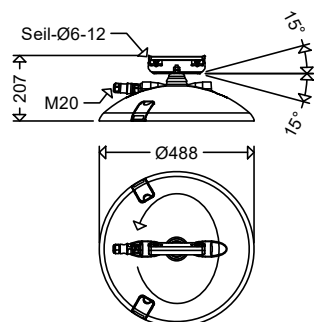

i

All light fittings also available with connected cable (H07RN-F or NYM) in the required length.

	55 REDONDO
Recommended mounting height	6 – 12 m
Wind-exposed surface	0.05 m ²
Luminous flux (LF 740)	3,210 – 17,520 lm
Luminous flux (LF 740) VARIO / NFC	1,470 – 16,730 lm
Luminous flux (LF 730)	3,050 – 16,640 lm
Luminous flux (LF 730) VARIO / NFC	1,400 – 15,890 lm
Connected load	17 – 106 W
Connected load VARIO / NFC	9 – 106 W
Luminous efficiency (LF 740)	158 – 189 lm/W
Luminous efficiency (LF 740) VARIO / NFC	158 – 191 lm/W
Luminous efficiency (LF 730)	150 – 179 lm/W
Luminous efficiency (LF 730) VARIO / NFC	150 – 182 lm/W
Optics	SB
Light colours	740, 730, 722, 518
Control functions	LR, LA, CL, DIMD
Light management	LIMAS Air SYNC, RFL
Variable luminous flux setting	VARIO / NFC
IP rating	IP66
Protection class (standard/option)	I / II
ECG	220 – 240 V, 50 – 60 Hz
Overvoltage protection	10 kV
LED module	Highpower, Zhaga-konform
Service life	L90 > 100,000 h
Energy efficiency class	B

Optionen:

Seawater-resistant version, special painting in RAL colours

MAXIMUM EFFICIENCY OR LOWEST INVESTMENT COSTS

When solving your lighting task, you often have the choice between maximum energy efficiency and the lowest initial investment. Compare and choose the optimum solution for your project.

The standard versions of the series are listed in the table. Customised lumen packages can be programmed at the factory.

Standard types

Type	Connected load [W]	Luminous flux [lm]		Luminous efficiency [lm/W]		Weight [kg]
		LF 740	LF 730	LF 740	LF 730	
55 1601 FC	17	3,210	3,050	189	179	7.1
55 1602 FC	25	4,480	4,260	179	170	7.1
55 1603 FC	35	6,070	5,770	173	165	7.1
55 3201 FC	34	6,420	6,100	189	179	7.2
55 3202 FC	50	8,950	8,500	179	170	7.2
55 3203 FC	70	12,080	11,480	173	164	7.2
55 4801 FC	52	9,060	8,610	174	166	7.4
55 4802 FC	75	12,550	11,920	167	159	7.4
55 4803 FC	106	16,730	15,890	158	150	7.4
55 6401 FC	69	12,580	11,950	182	173	7.5
55 6402 FC	99	17,520	16,640	177	168	7.5
55 L50 VARIO / NFC FC	9	1,470	1,400	163	156	7.1
	15	2,780	2,640	185	176	7.1
	18	3,420 ¹⁾	3,250 ¹⁾	190	181	7.1
	35	6,070	5,770	173	165	7.1
55 L100 VARIO / NFC FC	16	2,950	2,800	184	175	7.2
	38	7,270	6,910	191	182	7.2
	54	9,760 ¹⁾	9,270 ¹⁾	181	172	7.2
	70	12,080	11,480	173	164	7.2
55 L150 VARIO / NFC FC	24	4,190	3,980	175	166	7.4
	45	7,870	7,480	175	166	7.4
	82	13,640	12,960	166	158	7.4
	106	16,730 ¹⁾	15,890 ¹⁾	158	150	7.4

The luminaires are available with other optics, light colours, control functions and light management. (see "Technical features")

¹⁾ Factory settings





KONIC

SERIES 544 G2



A classic shape with a modern twist - that's how the KONIC wins over onlookers. With its refined design, it is reminiscent of traditional pole-top light fittings, but it's completely different when it comes to material and technology. The minimalistic design fits

into all town environments subtly and harmoniously. It adds ambience to promenades, park areas, squares and pedestrian zones as well as enhancing traffic-calmed zones and residential streets, providing light ranging from warm white to amber

(1,800 K) depending on the version. The BlackEdition version also contributes to protecting the night sky from unnecessary light pollution with an ULOR of 0 %.



Advantages

- Long-lasting, corrosion resistant aluminium housing
- Excellent thermal management due to direct adaption of the LED-modules to the aluminium housing
- EVG with high surge voltage resistance 10 kV
- Service life L90 > 100,000 hours
- Homogeneous illumination due to the Multi-Layer-Technology
- Removable upper part of the housing allows time- and cost-saving mounting
- BlackEdition, ULOR = 0 %
- Sustainable, control gear and LED-module replaceable by qualified personnel on-site
- Future proof by using standardized LED-modules (Zhaga) and long-term availability of spare parts

Main uses

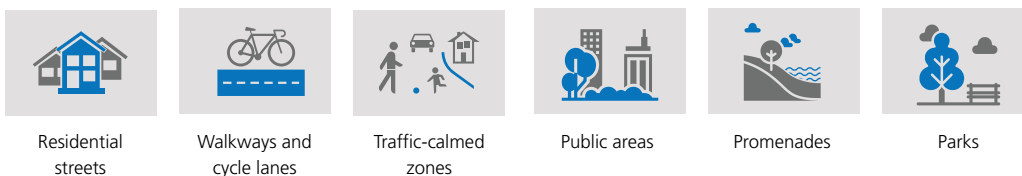



Flat safety glass, impact resistance IK09

Optics highly efficient lens optics for optimum light beam

LED module highly efficient, long-lasting high-power LED. Zhaga conformity ensures long-term availability of standardised modules for later replacement requirements

3-piece housing made of die-cast aluminium, powder-coated DB 702 (micro iron), consisting of mast base, connecting struts and roof

Connection box with isolating plug and strain relief for tool-free disconnection of the luminaire from the power supply

ECG high quality and durable with high surge voltage resistance of 10 kV

Mounting on straight light poles with a braid diameter of 76 mm. A reducer is available for poles with a diameter of 60 mm.



TECHNICAL PROPERTIES

Series 544 G2 KONIC

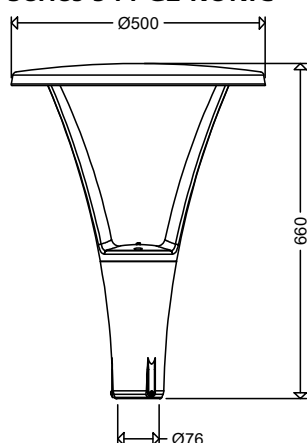

All light fittings also available with connected cable (H07RN-F or NYM) in the required length.

	544 G2 KONIC
Recommended mounting height	3 - 5 m
Wind-exposed surface	0.07 m ²
Luminous flux (LF 740)	1,410 - 7,750 lm
Luminous flux (LF 740)VARIO / NFC	640 - 10,080 lm
Luminous flux (LF 730)	1,340 - 7,360 lm
Luminous flux (LF 730) VARIO / NFC	610 - 9,580 lm
Connected load	9 - 53 W
Connected load VARIO / NFC	5 - 70 W
Luminous efficiency (LF 740)	146 - 161 lm/W
Luminous efficiency (LF 740) VARIO / NFC	128 - 162 lm/W
Luminous efficiency (LF 730)	139 - 152 lm/W
Luminous efficiency (LF 730) VARIO / NFC	122 - 154 lm/W
Optics	AB, ABL, RWX, RNX, R
Light colours	740, 730, 722, 518
Control functions	LR, LA, CL, DIMD
Light management	LIMAS Air SYNC, RFL
Variable luminous flux setting	VARIO / NFC
IP rating	IP65
Protection class (standard/option)	II / I
ECG	220 - 240 V, 50 - 60 Hz
IK rating	10 kV
LED module	Highpower, Zhaga compliant
Service life	L90 > 100,000 h
Energy efficiency class	C

Options:

Backside light shielding, seawater-resistant version, special painting in RAL colours

MAXIMUM EFFICIENCY OR LOWEST INVESTMENT COSTS

When solving your lighting task, you often have the choice between maximum energy efficiency and the lowest initial investment. Compare and choose the optimum solution for your project.

The standard versions of the series are listed in the table. Customised lumen packages can be programmed at the factory.

Standard types

Asymmetrical wide beam

Type	Connected load [W]	Luminous flux [lm]		Luminous efficiency [lm/W]		Weight [kg]
		LF 740	LF 730	LF 740	LF 730	
544 0801 G2	9	1,410	1,340	157	149	9.5
544 0802 G2	13	1,970	1,870	152	144	9.5
544 0803 G2	18	2,680	2,550	149	142	9.5
544 1601 G2	17	2,730	2,590	161	152	9.6
544 1602 G2	25	3,820	3,630	153	145	9.6
544 1603 G2	35	5,180	4,920	148	141	9.6
544 2401 G2	26	4,110	3,900	158	150	9.7
544 2402 G2	37	5,730	5,440	155	147	9.7
544 2403 G2	53	7,750	7,360	146	139	9.7
544 L25 G2 VARIO / NFC	5	640	610	128	122	9.5
	9	1,410	1,340	157	149	9.5
	13	1,970	1,870	152	144	9.5
	18	2,680 ¹⁾	2,550	149	142	9.5
544 L50 G2 VARIO / NFC	9	1,250	1,190	139	132	9.6
	15	2,370	2,250	158	150	9.6
	18	2,920 ¹⁾	2,770	162	154	9.6
	35	5,180	4,920	148	141	9.6
544 L100 G2 VARIO / NFC	16	2,460	2,340	154	146	9.8
	38	6,070	5,770	160	152	9.8
	54	8,140 ¹⁾	7,730	151	143	9.8
	70	10,080	9,580	144	137	9.8

The luminaires are available with other optics, light colours, control functions and light management. (see "Technical features")

¹⁾ Factory settings

INSTALLATION MADE EASY

The removable upper part of the housing makes installation easy, saving time and money.

- Mount the mast base
- Pull out the terminal block with the disconnect plug, connect the power cable and slide the terminal block back into the mast base
- Plug in the disconnect plug and mount the upper section – DONE

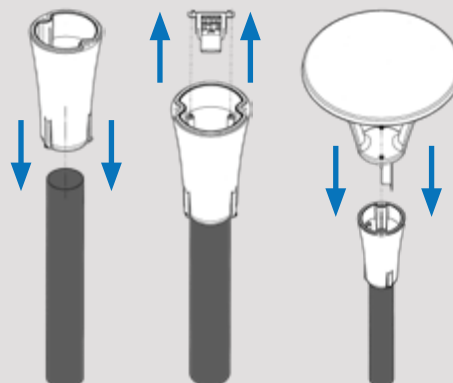



CUPINA / PLANEO

SERIES 556 G2 / 557 G2



CUPINA

A stepped dome roof and a cylindrical glass shape, these are the defining design features of this popular series. From a technology point of view, it unites the latest LED standards along with exceptional variant diversity. Completely revised in terms of design, Generation 2 of the CUPINA is oriented towards the specifications of the European Union with regard to sustainable product design. The CUPINA has a recycling-friendly modular design and the ECG and LED board can be replaced completely without tools. The LED board is integrated into the luminaire in such a way that there is no direct light emission into the upper half-space (BlackEdition: ULOR=0%). This is not only extremely environmentally friendly, but also enables eligibility for funding under the municipal guidelines.

PLANEO

With its flat roof and the straight lines of its design vocabulary, the PLANEO slips seamlessly into the town environment without being obtrusive. From a technology point of view, it unites the latest LED standards along with exceptional variant diversity. Completely revised in terms of design, Generation 2 of the PLANEO is oriented towards the specifications of the European Union with regard to sustainable product design. The PLANEO has a recycling-friendly modular design and the ECG and LED board can be replaced completely without tools. The LED board is integrated into the luminaire in such a way that there is no direct light emission into the upper half-space (BlackEdition: ULOR=0%). This is not only extremely environmentally friendly, but also enables eligibility for funding under the municipal guidelines.



Advantages

- Optimized thermal management due to direct adaption of the LED-modules to the heat sink
- EVG with high surge voltage resistance 10 kV
- Service life L90 > 100,000 hours
- Homogeneous illumination due to the Multi-Layer-Technology
- Optimal light distribution due to highly efficient lens optics with direct beam
- Quick installation, maintenance and conversion thanks to tool-free opening of the light fitting and tool-free replacement of the electrical components (LED module and ECG unit)
- BlackEdition, ULOR = 0 % (Modifications with accessories influence the light distribution)
- Eco-friendly, versions dimmable to 10 % with luminous fluxes up to 2000 lm and with color temperature up to 3,000 K comply with Dark Sky requirements
- Sustainable, control gear and LED-module replaceable by qualified personnel on-site
- Future proof by using standardized LED-modules (Zhaga) and long-term availability of spare parts

Main uses

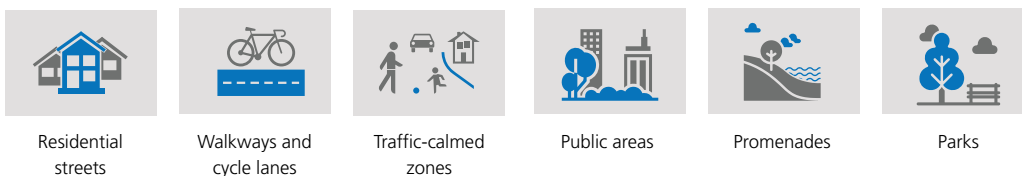

Luminaire roof made of aluminium, powder-coated DB 702 (mica iron)

LED module highly efficient, long-lasting high-power LED. Zhaga conformity ensures long-term availability of standardised modules for later replacement requirements

Optics highly efficient lens optics for optimum light beam

PMMA glass, cylindrical, clear

Electric block with insulating plug connection, strain relief and ECG, wired ready for connection, can be replaced without tools

ECG high quality and durable with high surge voltage resistance of 10 kV

ECG gear tray, can be replaced without tools

Mast base made of die-cast aluminium, powder-coated DB 702 (mica iron)

Mounting on straight light poles with a braid diameter of 76 mm. A reducer is available for poles with a diameter of 60 mm.



Video:
Assembly and
component
replacement



Electric block



TECHNICAL PROPERTIES

Series 556 G2 CUPINA

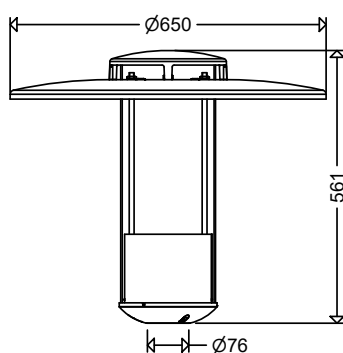

Series 557 G2 PLANEO

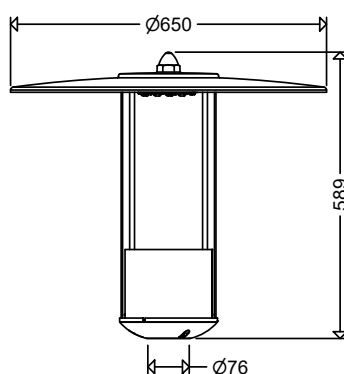

All light fittings also available with connected cable (H07RN-F or NYM) in the required length.

	556 G2 CUPINA	557 G2 PLANEO
Recommended mounting height	3 - 5 m	
Wind-exposed surface	0.13 m ²	
Luminous flux (LF 740)	1,430 - 5,280 lm	
Luminous flux (LF 740)VARIO / NFC	660 - 5,280 lm	
Luminous flux (LF 730)	1,360 - 5,020 lm	
Luminous flux (LF 730) VARIO / NFC	630 - 5,020 lm	
Connected load	9 - 35 W	
Connected load VARIO / NFC	5 - 35 W	
Luminous efficiency (LF 740)	149 - 168 lm/W	
Luminous efficiency (LF 740) VARIO / NFC	132 - 169 lm/W	
Luminous efficiency (LF 730)	142 - 159 lm/W	
Luminous efficiency (LF 730) VARIO / NFC	126 - 161 lm/W	
Optics	AB, ABL, RWX, RNX, R	
Light colours	740, 730, 722, 518	
Control functions	LR, LA, CL, DIMD	
Light management	LIMAS Air SYNC, RFL	
Variable luminous flux setting	VARIO / NFC	
IP rating	IP54	
Protection class (standard/option)	II / I	
ECG	220 - 240V, 50 - 60 Hz	
IK rating	10 kV	
LED module	Highpower, Zhaga compliant	
Service life	L90 > 100,000 h	
Energy efficiency class	B	

Options:

Seawater-resistant version, for connection to a central power supply system, special painting in RAL colours

STANDARD TYPES

The standard versions of the series are listed in the table. Customised lumen packages can be programmed at the factory.

Asymmetrical wide beam

Type	Connected load [W]	Luminous flux [lm]		Luminous efficiency [lm/W]		Weight [kg]
		LF 740	LF 730	LF 740	LF 730	
556 0801 G2	9	1,430	1,360	159	151	6.7
556 0802 G2	13	2,000	1,900	154	146	6.7
556 0803 G2	18	2,690	2,560	149	142	6.7
556 1601 G2	17	2,850	2,710	168	159	6.8
556 1602 G2	25	3,950	3,750	158	150	6.8
556 1603 G2	35	5,280	5,020	151	143	6.8
556 L25 G2 VARIO / NFC	5	660	630	132	126	6.7
	9	1,430	1,360	159	151	6.7
	13	2,000	1,900	154	146	6.7
	18	2,690 ¹⁾	2,560	149	142	6.7
556 L50 G2 VARIO / NFC	9	1,320	1,250	147	139	6.8
	15	2,470	2,350	165	157	6.8
	18	3,040 ¹⁾	2,890	169	161	6.8
	35	5,280	5,020	151	143	6.8

Type	Connected load [W]	Luminous flux [lm]		Luminous efficiency [lm/W]		Weight [kg]
		LF 740	LF 730	LF 740	LF 730	
557 0801 G2	9	1,430	1,360	159	151	5.9
557 0802 G2	13	2,000	1,900	154	146	5.9
557 0803 G2	18	2,690	2,560	149	142	5.9
557 1601 G2	17	2,850	2,710	168	159	6.0
557 1602 G2	25	3,950	3,750	158	150	6.0
557 1603 G2	35	5,280	5,020	151	143	6.0
557 L25 G2 VARIO / NFC	5	660	630	132	126	5.9
	9	1,430	1,360	159	151	5.9
	13	2,000	1,900	154	146	5.9
	18	2,690 ¹⁾	2,560	149	142	5.9
557 L50 G2 VARIO / NFC	9	1,320	1,250	147	139	6.0
	15	2,470	2,350	165	157	6.0
	18	3,040 ¹⁾	2,890	169	161	6.0
	35	5,280	5,020	151	143	6.0

The luminaires are available with other optics, light colours, control functions and light management. (see "Technical features")

¹⁾ Factory settings

POLE-TOP BRACKETS

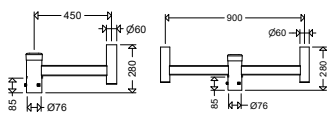

Pole-top brackets Ø 60mm

Type	Description	Weight [kg]	for following light fittings:
MAU 625/1	for 1 fitting	4.6	541, 543, 553, 556, 557, 558, 544, (with RZ 1)
MAU 625/2	for 2 fittings	7.0	

VERSION WITH RING MIRROR

For aesthetic reasons, the luminaires can also be equipped with an aluminium ring mirror as a design element. Also, a frosted board cover and backside light shielding are available. Please note: such modifications influence the light distribution.





CILA

SERIES 558 G2



The series CILA embodies pure elegance. Reduced to the essential, it fits harmoniously in every environment and perfectly complements the series CUPINA and PLANE0 with their cylindric cover shape. The frosted LED covers provide a homogenous illumination, an excellent glare limitation and a comfortable perception of light. Technically, the CILA is at a high level, as documented by its

long service life of over 100,000 hours. A variety of options, that leaves hardly anything to be desired, are available, e.g. the light management system LIMAS Air SYNC. Completely revised in terms of design, Generation 2 of the CILA is oriented towards the specifications of the European Union with regard to sustainable product design. The CILA has a recycling-friendly modular design

and the ECG and LED board can be replaced completely without tools. The LED board is integrated into the luminaire in such a way that there is no direct light emission into the upper half-space (BlackEdition: ULOR=0%). This is not only extremely environmentally friendly, but also enables eligibility for funding under the municipal guidelines.



Advantages

- Optimized thermal management due to direct adaption of the LED-modules to the heat sink
- EVG with high surge voltage resistance 10 kV
- Service life L90 > 100,000 hours
- Homogeneous illumination due to the Multi-Layer-Technology
- Optimal light distribution due to highly efficient lens optics with direct beam
- Quick installation, maintenance and conversion thanks to tool-free opening of the light fitting and tool-free replacement of the electrical components (LED module and ECG unit)
- BlackEdition, ULOR = 0 % (Modifications with accessories influence the light distribution)
- Eco-friendly, versions dimmable to 10 % with luminous fluxes up to 2000 lm and with color temperature up to 3,000 K comply with Dark Sky requirements
- Sustainable, control gear and LED-module replaceable by qualified personnel on-site
- Future proof by using standardized LED-modules (Zhaga) and long-term availability of spare parts

Main applications



Residential streets



Traffic-calmed zones



Public areas



Promenades



Parks

Aluminium cover made of aluminium, powder-coated DB 702 (mica iron)

LED module highly efficient, long-lasting high-power LED. Zhaga conformity ensures long-term availability of standardised modules for later replacement requirements

Optics highly efficient lens optics for optimum light beam

PMMA glass, cylindrical, clear

Electric block with insulating plug connection, strain relief and ECG, wired ready for connection, can be replaced without tools

ECG high quality and durable with high surge voltage resistance of 10 kV

ECG gear tray, can be replaced without tools

Mast base made of die-cast aluminium, powder-coated DB 702 (mica iron)

Mounting on straight light poles with a thread diameter of 76 mm. A reducer is available for poles with a diameter of 60 mm.



Video:
Assembly and
component
replacement

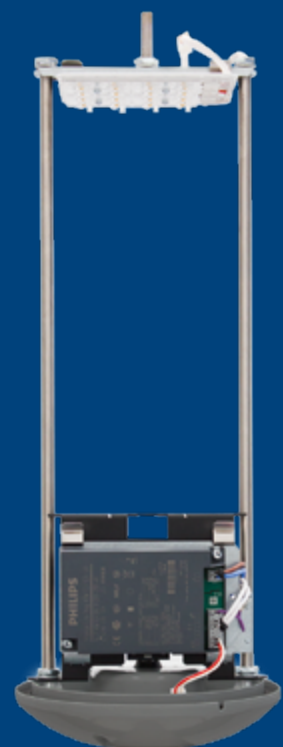

Electric block



TECHNICAL PROPERTIES

Series 558 G2 CILA

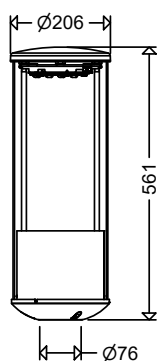

All light fittings also available with connected cable (H07RN-F or NYM) in the required length.

	558 G2 CILA
Recommended mounting height	3 - 5 m
Wind-exposed surface	0.11 m ²
Luminaire luminous flux (LF 740)	1,430 - 5,280 lm
Luminaire luminous flux (LF 740) VARIO / NFC	660 - 5,280 lm
Luminaire luminous flux (LF 730)	1,360 - 5,020 lm
Luminaire luminous flux (LF 730) VARIO / NFC	630 - 5,020 lm
Connected load	9 - 35 W
Connected load VARIO / NFC	5 - 35 W
Luminous efficacy (LF 740)	149 - 168 lm/W
Luminous efficacy (LF 740) VARIO / NFC	132 - 169 lm/W
Luminous efficacy (LF 730)	142 - 159 lm/W
Luminous efficacy (LF 730) VARIO / NFC	126 - 161 lm/W
Optics	AB, ABL, RWX, RNX, R
Light colours	740, 730, 722, 518
Control functions	LR, LA, CL, DIMD
Light management	LIMAS Air SYNC, RFL
Variable luminous flux setting	VARIO / NFC
IP rating	IP54
Protection class (standard / option)	II / I
ECG	220 - 240 V, 50 - 60 Hz
IK rating	10 kV
LED module	Highpower, Zhaga compliant
Service life	L90 > 100,000 h
Energy efficiency class	B

Options:

Seawater-resistant version, for connection to a central power supply system, special painting in RAL colours

STANDARD TYPES

The standard versions of the series are listed in the table. Customised lumen packages can be programmed at the factory.

asymmetrical wide distribution

Type	Connected load [W]	Luminaire luminous flux [lm]		Luminous efficiency [lm/W]		Weight [kg]
		LF 740	LF 730	LF 740	LF 730	
558 0801 G2	9	1.430	1.360	159	151	4,7
558 0802 G2	13	2.000	1.900	154	146	4,7
558 0803 G2	18	2.690	2.560	149	142	4,7
558 1601 G2	17	2.850	2.710	168	159	4,8
558 1602 G2	25	3.950	3.750	158	150	4,8
558 1603 G2	35	5.280	5.020	151	143	4,8
558 L25 G2 VARIO / NFC	5	660	630	132	126	4,7
	9	1.430	1.360	159	151	4,7
	13	2.000	1.900	154	146	4,7
	18	2.690 ¹⁾	2.560	149	142	4,7
558 L50 G2 VARIO / NFC	9	1.320	1.250	147	139	4,8
	15	2.470	2.350	165	157	4,8
	18	3.040 ¹⁾	2.890	169	161	4,8
	35	5.280	5.020	151	143	4,8

The luminaires are available with additional optics, light colours, control functions and light management. (see "Technical properties")

¹⁾ Factory settings

VERSION WITH RING MIRROR

For aesthetic reasons, the luminaires can also be equipped with an aluminium ring mirror as a design element. Also, a frosted board cover and backside light shielding are available. Please note: such modifications influence the light distribution.

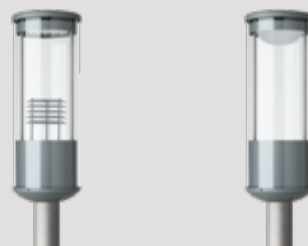



CAPA

SERIES 541 G2



Attractive, rounded shapes characterise CAPA. Their look & feel is strongly evocative of the traditional conical pole-top design even though the cover is cylindrical. In particular in residential areas in town centres where there are lots of older building and in historical centres, these light fittings have a distinctive appeal. Completely revised in terms of design, Generation 2 of the CAPA is

oriented towards the specifications of the European Union with regard to sustainable product design. The CAPA has a recycling-friendly modular design and the ECG and LED board can be replaced completely without tools. The LED board is integrated into the luminaire in such a way that there is no direct light emission into the upper half-space (BlackEdition: ULOR=0%). This is not

only extremely environmentally friendly, but also enables eligibility for funding under the municipal guidelines. Even really sensitive areas such as landscaped zones and conservation areas can be illuminated in accordance with requirements using warm light colours such as amber (1,800 K).



Advantages

- Optimized thermal management due to direct adaption of the LED-modules to the heat sink
- EVG with high surge voltage resistance 10 kV
- Service life L90 > 100,000 hours
- Homogeneous illumination due to the Multi-Layer-Technology
- Optimal light distribution due to highly efficient lens optics with direct beam
- Quick installation, maintenance and conversion thanks to tool-free opening of the light fitting and tool-free replacement of the electrical components (LED module and ECG unit)
- BlackEdition, ULOR = 0 % (Modifications with accessories influence the light distribution)
- Eco-friendly, versions dimmable to 10 % with luminous fluxes up to 2000 lm and with color temperature up to 3,000 K comply with Dark Sky requirements
- Sustainable, control gear and LED-module replaceable by qualified personnel on-site
- Future proof by using standardized LED-modules (Zhaga) and long-term availability of spare parts

Main applications

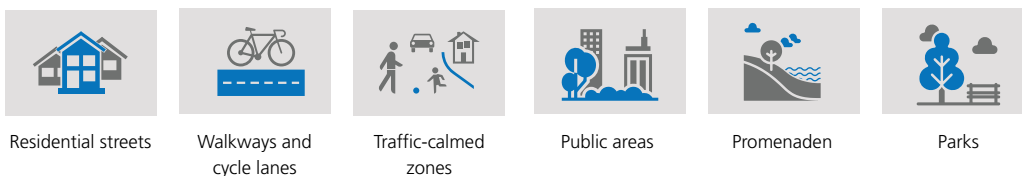

Luminaire roof made of aluminium, offset dome shape, powder-coated DB 702 (mica iron)

LED module highly efficient, long-lasting high-power LED. Zhaga conformity ensures long-term availability of standardised modules for later replacement requirements

Optics highly efficient lens optics for optimum light beam

PMMA glass, cylindrical, clear

Electric block with insulating plug connection, strain relief and ECG, wired ready for connection, can be replaced without tools

ECG high quality and durable with high surge voltage resistance of 10 kV

ECG gear tray, can be replaced without tools

Mast base made of die-cast aluminium, powder-coated DB 702 (mica iron)

Mounting on straight light poles with a braid diameter of 76 mm. A reducer is available for poles with a diameter of 60 mm.



Video:
Assembly and
component
replacement



Electric block



TECHNICAL PROPERTIES

Series 541 G2 CAPA

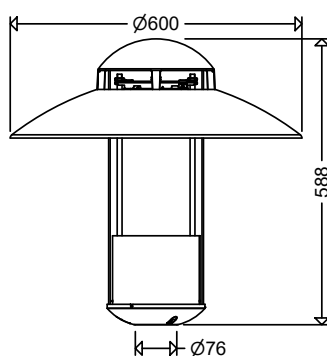

i

All light fittings also available with connected cable (H07RN-F or NYM) in the required length.

	541 G2 CAPA
Recommended mounting height	3 - 5 m
Wind-exposed surface	0.13 m ²
Luminaire luminous flux (LF 740)	1,380 - 5,080 lm
Luminaire luminous flux (LF 740) VARIO / NFC	630 - 5,080 lm
Luminaire luminous flux (LF 730)	1,310 - 4,830 lm
Luminaire luminous flux (LF 730) VARIO / NFC	600 - 4,830 lm
Connected load	9 - 35 W
Connected load VARIO / NFC	5 - 35 W
Luminous efficacy (LF 740)	144 - 161 lm/W
Luminous efficacy (LF 740) VARIO / NFC	126 - 162 lm/W
Luminous efficacy (LF 730)	137 - 153 lm/W
Luminous efficacy (LF 730) VARIO / NFC	120 - 154 lm/W
Optics	AB, ABL, RWX, RNX, R
Light colours	740, 730, 722, 518
Control functions	LR, LA, CL, DIMD
Light management	LIMAS Air SYNC, RFL
Variable luminous flux setting	VARIO / NFC
IP rating	IP54
Protection class (standard / option)	II / I
ECG	220 - 240 V, 50 - 60 Hz
IK rating	10 kV
LED module	Highpower, Zhaga compliant
Service life	L90 > 100,000 h
Energy efficiency class	B

Options:

Seawater-resistant version, for connection to a central power supply system, special painting in RAL colours

STANDARD TYPES

The standard versions of the series are listed in the table. Customised lumen packages can be programmed at the factory.

asymmetrical wide distribution

Type	Connected load [W]	Luminaire luminous flux [lm]		Luminous efficiency [lm/W]		Weight [kg]
		LF 740	LF 730	LF 740	LF 730	
541 0801 G2	9	1,380	1,310	153	146	7.1
541 0802 G2	13	1,920	1,820	148	140	7.1
541 0803 G2	18	2,590	2,460	144	137	7.1
541 1601 G2	17	2,740	2,600	161	153	7.2
541 1602 G2	25	3,800	3,610	152	144	7.2
541 1603 G2	35	5,080	4,830	145	138	7.2
541 L25 G2 VARIO / NFC	5	630	600	126	120	7.1
	9	1,380	1,310	153	146	7.1
	13	1,920	1,820	148	140	7.1
	18	2,590 ¹⁾	2,460	144	137	7.1
541 L50 G2 VARIO / NFC	9	1,270	1,210	141	134	7.2
	15	2,380	2,260	159	151	7.2
	18	2,920 ¹⁾	2,770	162	154	7.2
	35	5,080	4,830	145	138	7.2

The luminaires are available with additional optics, light colours, control functions and light management. (see "Technical properties")

¹⁾ Factory settings

VERSION WITH RING MIRROR

For aesthetic reasons, the luminaires can also be equipped with an aluminium ring mirror as a design element. Also, a frosted board cover and backside light shielding are available. Please note: such modifications influence the light distribution.

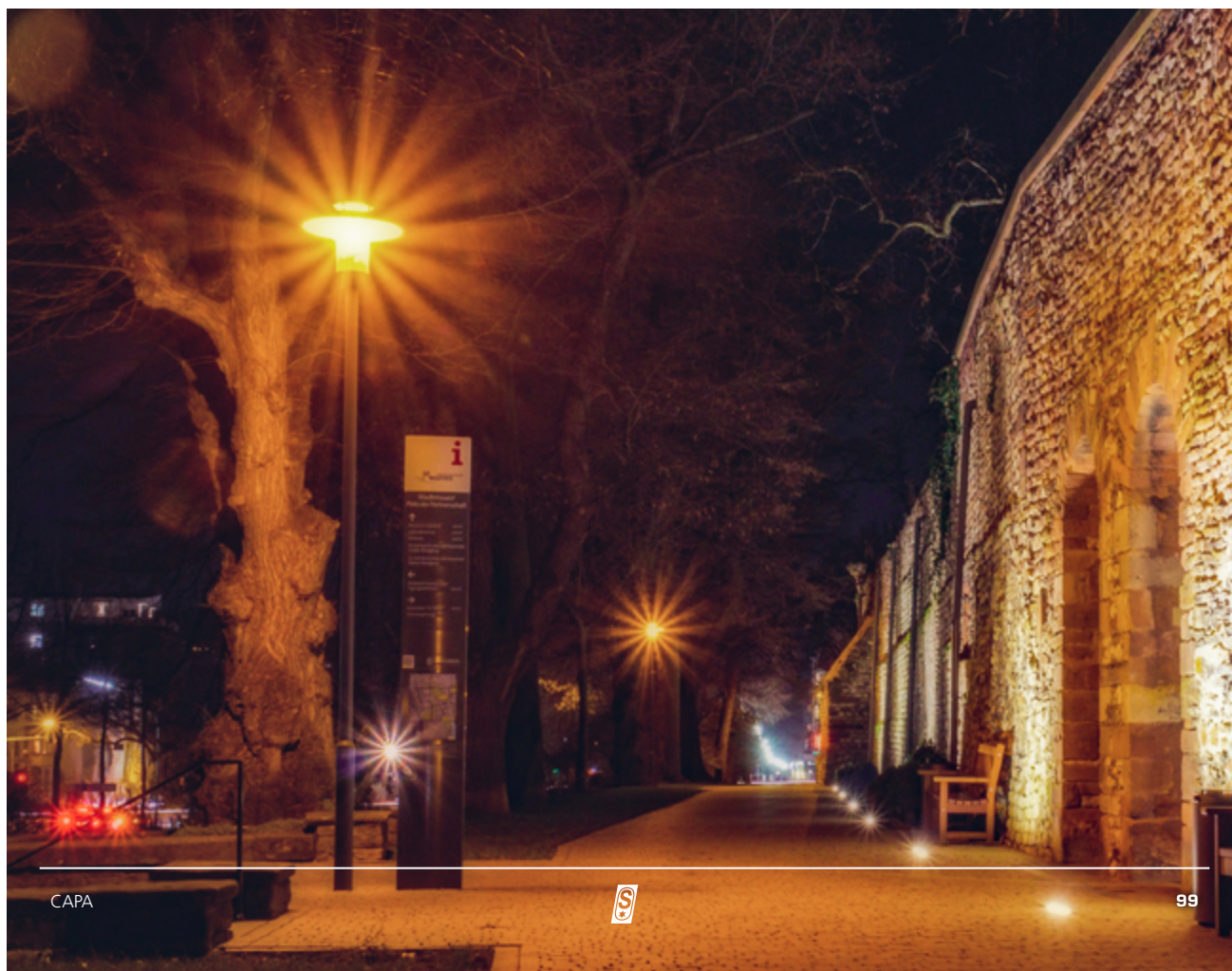



RETRO / RETRO Z

SERIES 543 G2 / 553 G2



RETRO

The RETRO is a classic member of pole-top light fitting range. Many users would agree that no compromises have been made with regard to attractiveness even in the LED version. Just like its traditional role model, it is supplied with a great-value polyester roof. If you want your roof painted in your desired colour, you should opt for an aluminium roof. Completely revised in terms of design, Generation 2 of the RETRO is oriented towards the specifications of the European Union with regard to sustainable product design. The RETRO has a recycling-friendly modular design and the ECG and LED board can be replaced completely without tools. The LED board is integrated into the luminaire in such a way that there is no direct light emission into the upper half-space (BlackEdition: ULOR=0%). This is not only extremely environmentally friendly, but also enables eligibility for funding under the municipal guidelines.

RETRO Z

The RETRO Z is based on traditional pole-top luminaires but has a cylindrical cover. Highly efficient optics ensure top light distribution, the multi-layer technology gives uniform illumination and the frosted cover over the LED module provides excellent glare limitation. Completely revised in terms of design, Generation 2 of the RETRO Z is oriented towards the specifications of the European Union with regard to sustainable product design. The RETRO Z has a recycling-friendly modular design and the ECG and LED board can be replaced completely without tools. The LED board is integrated into the luminaire in such a way that there is no direct light emission into the upper half-space (BlackEdition: ULOR=0%). This is not only extremely environmentally friendly, but also enables eligibility for funding under the municipal guidelines.



Advantages

- Optimized thermal management due to direct adaption of the LED-modules to the heat sink
- EVG with high surge voltage resistance 10 kV
- Service life L90 > 100,000 hours
- Homogeneous illumination due to the Multi-Layer-Technology
- Optimal light distribution due to highly efficient lens optics with direct beam
- Quick installation, maintenance and conversion thanks to tool-free opening of the light fitting and tool-free replacement of the electrical components (LED module and ECG unit)
- BlackEdition, ULOR = 0 % (Modifications with accessories influence the light distribution)
- Eco-friendly, versions dimmable to 10 % with luminous fluxes up to 2000 lm and with color temperature up to 3,000 K comply with Dark Sky requirements
- Sustainable, control gear and LED-module replaceable by qualified personnel on-site
- Future proof by using standardized LED-modules (Zhaga) and long-term availability of spare parts

Main applications



Residential streets



Walkways and cycle lanes



Traffic-calmed zones



Public areas



Promenades



Parks

Luminaire roof made of glass fibre reinforced polyester, colour similar to RAL 7035. Optionally available in aluminium, painted RAL 7035.

LED module highly efficient, long-lasting high-power LED. Zhaga conformity ensures long-term availability of standardised modules for later replacement requirements

Optics highly efficient lens optics for optimum light beam

PMMA glass, conical or cylindrical, clear

Electric block with insulating plug connection, strain relief and ECG, wired ready for connection, can be replaced without tools

ECG high quality and durable with high surge voltage resistance of 10 kV

ECG gear tray, can be replaced without tools

Mast base made of die-cast aluminium, painted to RAL 7035

Mounting on straight light poles with a thread diameter of 76 mm. A reducer is available for poles with a diameter of 60 mm.



Video:
Assembly and
component
replacement



Electric block



TECHNICAL PROPERTIES

Series 543 G2 RETRO

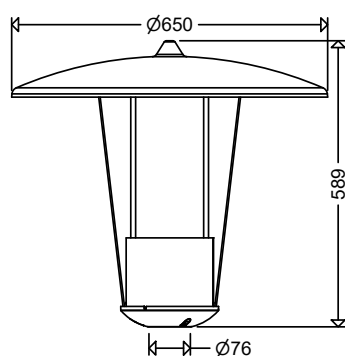

Series 553 G2 RETRO Z

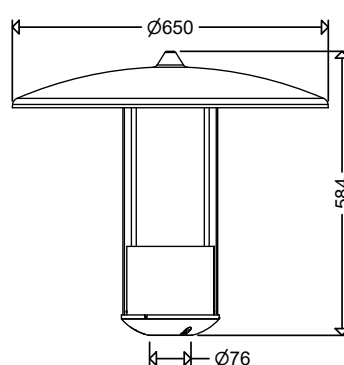

i

All light fittings also available with connected cable (H07RN-F or NYM) in the required length.

	543 G2 RETRO	553 G2 RETRO Z
Recommended mounting height	3 - 5 m	
Wind-exposed surface	0,13 m ²	
Luminaire luminous flux (LF 740)	1,430 - 5,280 lm	
Luminaire luminous flux (LF 740) VARIO / NFC	660 - 5,280 lm	
Luminaire luminous flux (LF 730)	1,360 - 5,020 lm	
Luminaire luminous flux (LF 730) VARIO / NFC	630 - 5,020 lm	
Connected load	9 - 35 W	
Connected load VARIO / NFC	5 - 35 W	
Luminous efficacy (LF 740)	149 - 168 lm/W	
Luminous efficacy (LF 740) VARIO / NFC	132 - 169 lm/W	
Luminous efficacy (LF 730)	142 - 159 lm/W	
Luminous efficacy (LF 730) VARIO / NFC	126 - 161 lm/W	
Optics	AB, ABL, RWX, RNX, R	
Light colours	740, 730, 722, 518	
Control functions	LR, LA, CL, DIMD	
Light management	LIMAS Air SYNC, RFL	
Variable luminous flux setting	VARIO / NFC	
IP rating	IP54	
Protection class (standard / option)	II / I	
ECG	220 - 240 V, 50 - 60 Hz	
IK rating	10 kV	
LED module	Highpower, Zhaga compliant	
Service life	L90 > 100,000 h	
Energy efficiency class	B	

Optionen:

Seawater-resistant version, for connection to a central power supply system, special painting in RAL colours

MAXIMUM EFFICIENCY OR LOWEST INVESTMENT COSTS

When solving your lighting task, you often have the choice between maximum energy efficiency and the lowest initial investment. Compare and choose the optimum solution for your project.

The standard versions of the series are listed in the table. Customised lumen packages can be programmed at the factory.

Standard types

asymmetrical extremely wide distribution

Type	Connected load [W]	Luminaire luminous flux [lm]		Luminous efficiency [lm/W]		Weight [kg]
		LF 740	LF 730	LF 740	LF 730	
543 0801 G2	9	1.430	1.360	159	151	7,0
543 0802 G2	13	2.000	1.900	154	146	7,0
543 0803 G2	18	2.690	2.560	149	142	7,0
543 1601 G2	17	2.850	2.710	168	159	7,1
543 1602 G2	25	3.950	3.750	158	150	7,1
543 1603 G2	35	5.280	5.020	151	143	7,1
543 L25 G2 VARIO / NFC	5	660	630	132	126	7,0
	9	1.430	1.360	159	151	7,0
	13	2.000	1.900	154	146	7,0
	18	2.690 ¹⁾	2.560	149	142	7,0
543 L50 G2 VARIO / NFC	9	1.320	1.250	147	139	7,1
	15	2.470	2.350	165	157	7,1
	18	3.040 ¹⁾	2.890	169	161	7,1
	35	5.280	5.020	151	143	7,1

Type	Connected load [W]	Luminaire luminous flux [lm]		Luminous efficiency [lm/W]		Weight [kg]
		LF 740	LF 730	LF 740	LF 730	
553 0801 G2	9	1,430	1,360	159	151	7.0
553 0802 G2	13	2,000	1,900	154	146	7.0
553 0803 G2	18	2,690	2,560	149	142	7.1
553 1601 G2	17	2,850	2,710	168	159	7.1
553 1602 G2	25	3,950	3,750	158	150	7.1
553 1603 G2	35	5,280	5,020	151	143	7.1
553 L25 G2 VARIO / NFC	5	660	630	132	126	7.0
	9	1,430	1,360	159	151	7.0
	13	2,000	1,900	154	146	7.0
	18	2,690 ¹⁾	2,560	149	142	7.0
553 L50 G2 VARIO / NFC	9	1,320	1,250	147	139	7.1
	15	2,470	2,350	165	157	7.1
	18	3,040 ¹⁾	2,890	169	161	7.1
	35	5,280	5,020	151	143	7.1

The luminaires are available with additional optics, light colours, control functions and light management. (see "Technical properties")

¹⁾ Factory settings

VERSION WITH RING MIRROR

For aesthetic reasons, the luminaires can also be equipped with an aluminium ring mirror as a design element. Also, a frosted board cover and backside light shielding are available. Please note: such modifications influence the light distribution.

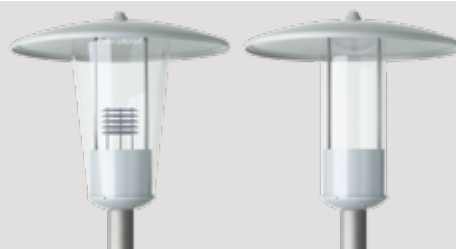



BELLA

SERIES 564 G2 / 565 G2

A classic in village and urban renewal, as well as for pedestrian zones, promenades and park areas. The pendant luminaires with their round arch pole-top adapters evoke a sense of nostalgia that fits in really well with areas containing old building and with the rural idyll of village centres. With warm light colours, these lights not only

create an atmospheric, cosy ambience that is held in particular regard by residents and town planners and that goes down really well, but also takes into account insect and nature conservation concerns, which are increasingly the focus of public lighting. Thanks to design changes in Generation 2, the components can now be replaced with-

hout tools. Light emissions into the upper half-space are avoided (ULOR=0), meaning that the luminaires are eligible for unrestricted subsidisation in accordance with the municipal guidelines.

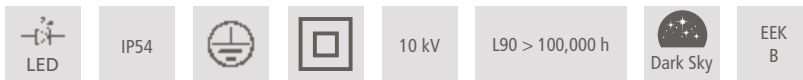

Advantages

- EVG with high surge voltage resistance 10 kV
- Service life L90 > 100,000 hours
- Good glare limitation due to low-lying pearled cover
- Homogeneous illumination due to the Multi-Layer-Technology
- Comfortable perception of light and brilliant glare limitation through pearled cover
- Quick maintenance and change of components due to tool-free exchangeable gear-tray system (electrical block)
- Eco-friendly, no light emission into the upper half space, ULOR = 0
- Versions dimmable to 10 % and with color temperature up to 3,000 K comply with Dark Sky requirements
- Sustainable, control gear and LED-module replaceable by qualified personnel on-site
- Future proof by using standardised Zhaga LED modules

Main applications



Mounting on bow attachments with $\frac{3}{4}$ inch internal thread

Housing made of aluminium plate, powder-coated DB 702 (mica iron)

Electrical block with ECG, LED module and strain relief, wired ready for connection

ECG high quality and durable with high surge voltage resistance of 10 kV

LED module highly efficient, long-lasting high-power LED. Zhaga conformity ensures long-term availability of standardised modules for later replacement requirements

Optics highly efficient lens optics for optimum light beam

PMMA cover, clear pearled, slightly curved



Video:
Assembly and
component
replacement



TECHNICAL PROPERTIES

Series 564 G2 BELLA

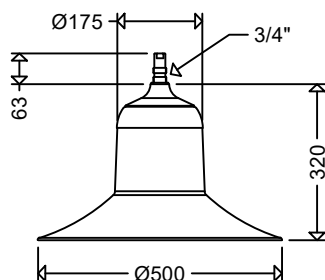

Series 565 G2 BELLA

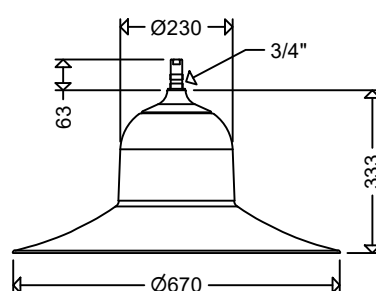

i

All light fittings also available with connected cable (H07RN-F or NYM) in the required length.

	564 G2 BELLA	565 G2 BELLA
Recommended mounting height	3 - 5 m	4 - 6 m
Wind-exposed surface	0.08 m ²	0.11 m ²
Luminaire luminous flux (LF 740)	1,510 - 5,580 lm	2,960 - 11,150 lm
Luminaire luminous flux (LF 740) VARIO / NFC	690 - 5,580 lm	1,360 - 11,150 lm
Luminaire luminous flux (LF 730)	1,430 - 5,300 lm	2,810 - 10,590 lm
Luminaire luminous flux (LF 730) VARIO / NFC	660 - 5,300 lm	1,290 - 10,590 lm
System performance	9 - 35 W	17 - 70 W
System performance VARIO / NFC	5 - 35 W	9 - 70 W
Luminous efficacy (LF 740)	158 - 176 lm/W	159 - 176 lm/W
Luminous efficacy (LF 740) VARIO / NFC	138 - 178 lm/W	151 - 178 lm/W
Luminous efficacy (LF 730)	150 - 168 lm/W	151 - 167 lm/W
Luminous efficacy (LF 730) VARIO / NFC	132 - 169 lm/W	143 - 169 lm/W
Optics	AB, R, RWX	
Light colours	740, 730, 722, 518	
Control functions	LR, LA, CL, DIMD	
Light management	-	
Variable luminous flux setting	VARIO / NFC	
IP rating	IP54	
Protection class (standard / option)	I / II	
ECG	220 - 240 V, 50 - 60 Hz	
IK rating	10 kV	
LED module	Highpower, Zhaga compliant	
Service life	L90 > 100,000 h	
Energy efficiency class	B	

Options:

Seawater-resistant version, special painting in RAL colours

STANDARD TYPES

The standard versions of the series are listed in the table. Customised lumen packages can be programmed at the factory.

Type	Connected load [W]	Luminaire luminous flux [lm]		Luminous efficiency [lm/W]		Weight [kg]
		LF 740	LF 730	LF 740	LF 730	
564 0801 G2	9	1,510	1,430	168	159	2.8
564 0802 G2	13	2,100	2,000	162	154	2.8
564 0803 G2	18	2,840	2,700	158	150	2.8
564 1601 G2	17	3,000	2,850	176	168	2.8
564 1602 G2	25	4,170	3,960	167	158	2.8
564 1603 G2	35	5,580	5,300	159	151	2.8
564 L25 G2 VARIO	5	690	660	138	132	2.8
	9	1,510	1,430	168	159	2.8
	13	2,100	2,000	162	154	2.8
	18	2,840 ¹⁾	2,700	158	150	2.8
564 L50 G2 VARIO	9	1,390	1,320	154	147	2.8
	15	2,610	2,480	174	165	2.8
	18	3,200 ¹⁾	3,040	178	169	2.8
	35	5,580	5,300	159	151	2.8

Type	Connected load [W]	Luminaire luminous flux [lm]		Luminous efficiency [lm/W]		Weight [kg]
		LF 740	LF 730	LF 740	LF 730	
565 1601 G2	17	2,960	2,810	174	165	4.4
565 1602 G2	25	4,130	3,920	165	157	4.4
565 1603 G2	35	5,580	5,300	159	151	4.4
565 3201 G2	34	5,990	5,690	176	167	4.5
565 3202 G2	50	8,300	7,890	166	158	4.5
565 3203 G2	70	11,150	10,590	159	151	4.5
565 L50 G2 VARIO	9	1,360	1,290	151	143	4.4
	15	2,560	2,430	171	162	4.4
	18	3,160 ¹⁾	3,000	176	167	4.4
	35	5,580	5,300	159	151	4.4
565 L100 G2 VARIO	16	2,760	2,620	173	164	4.5
	38	6,760	6,420	178	169	4.5
	54	9,050 ¹⁾	8,600	168	159	4.5
	70	11,150	10,590	159	151	4.5

The luminaires are available with additional optics, light colours, control functions and light management. (see "Technical features")

¹⁾ Factory settings

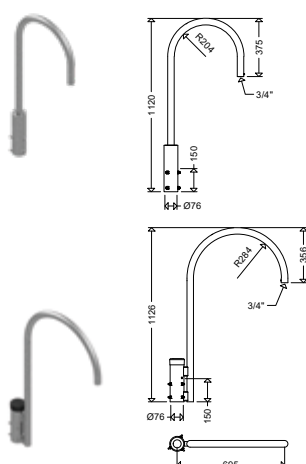

MAST TOPS

Round arch pole-top adapter for pendant lights

Type	Description	Weight [kg]
MAU 619/1	for 1 fitting	8.8
MAU 722/1	for 1 fitting	8.2
MAU 722/2	for 2 fittings	14.0
MAU 722/3	for 3 fittings	19.9
MAU 722/4	for 4 fittings	25.7



FOCO

SERIES 7600 VARIO



Complex type diversity? Unsure about the selection? Unsatisfied with the result? With the FOCO 7600 Vario, this can't happen. Thanks to the variably adjustable luminous flux, it offers illumination just as you want it - flexibly, simply and universally. The luminous flux can be adjusted at any time com-

pletely without tools, at the workshop, when being erected on-site and even subsequently if changed conditions make it necessary. You will not want to miss out on this flexibility, especially when lighting areas close to buildings and illuminating buildings and facades. This is because you

can adjust the luminous flux completely flexibly until you are satisfied with the result. It couldn't be easier.

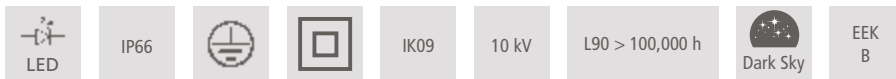
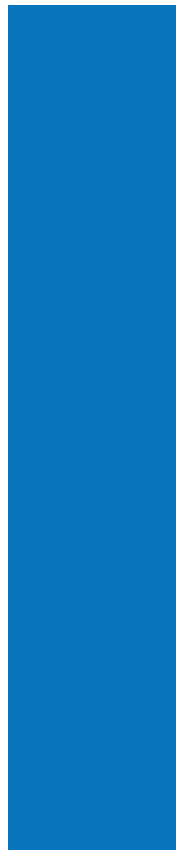

EEK
B

Vorteile

- Reduction of type diversity due to variably adjustable luminous flux
- Tool-free adjustment of luminous flux using DIP switch, can be changed at any time
- High flexibility due to almost infinitely variable luminous flux setting
- Perfect thermal management due to direct connection of the LED modules to the housing
- Homogeneous illumination due to the Multi-Layer-Technology
- Optimal light distribution due to highly efficient optics
- Quick electrical connection due to outlaying electrical connection box
- Eco-friendly, no light emission into the upper half-space, ULOR = 0 (Plane Surface Floodlight)
- Versions dimmable to 10 % with luminous fluxes up to 2000 lm and with color temperature up to 3,000 K comply with Dark Sky requirements
- Sustainable, control gear and LED-module replaceable by qualified personnel on-site
- Future proof by using standardized LED-modules (Zhaga) and long-term availability of spare parts
- GreenLine luminaire, outstanding sustainable design

Main applications



Car parks



Loading areas



Stockyards



Farmyards



Vehicle depots



Building and
facade lighting

Die-cast aluminium housing, powder-coated DB 702 (mica iron)

Optics highly efficient lens optics for optimum light beam

LED module highly efficient, long-lasting high-power LED. Zhaga conformity ensures long-term availability of standardised modules for later replacement requirements

Flat safety glass, resistant to temperature changes, impact resistance IK09



Cover plate prevents view into the interior of the luminaire

ECG high quality and durable with high surge voltage resistance of 10 kV

DIP switch on VARIO version for tool-free adjustment of luminous flux, easily accessible via the connection box accessible from the outside

Mounting bracket can be rotated through 180°



OPTICS

Depending on the application and light point height, you can choose between wide, deep wide, deep, extremely deep and asymmetrical beam patterns. In addition, all street and cycle path optics can also be used in the luminaires. Expert advice and lighting design will help you make the right decision.

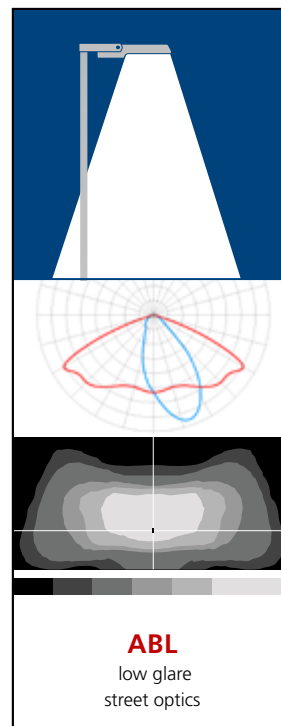
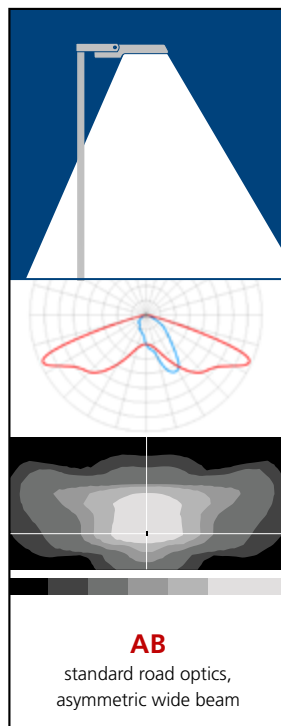
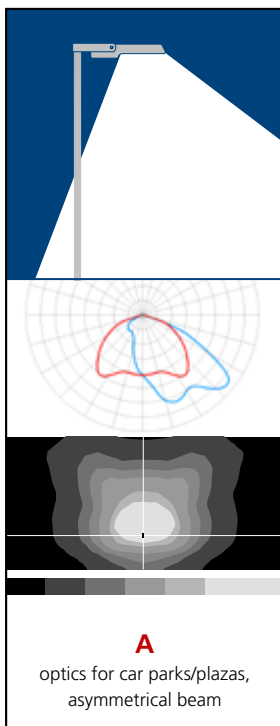
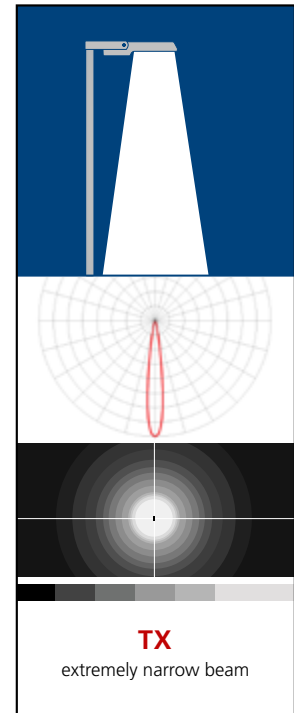
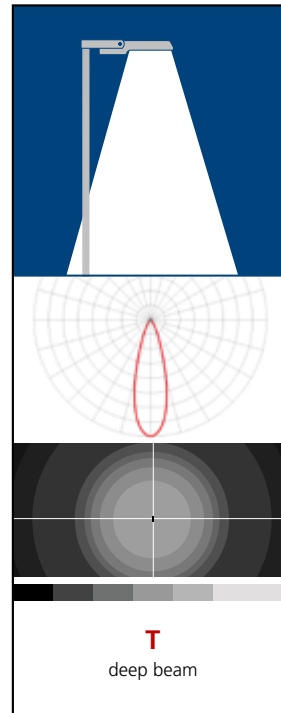
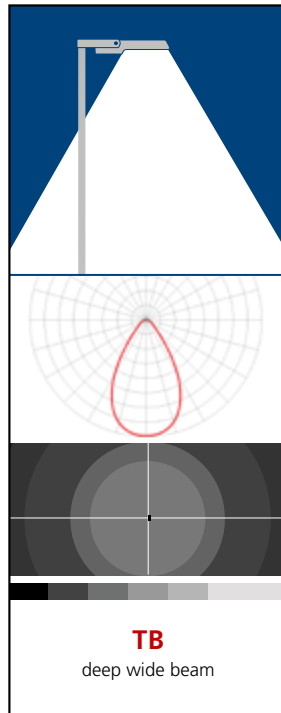
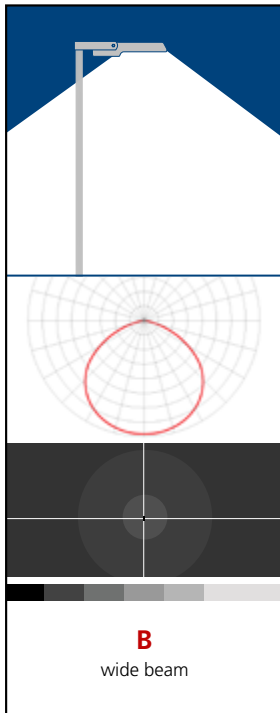



LUMINOUS FLUX SETTING

VARIO version:

Here, the luminous flux is adjusted manually via the DIP switch in the connection compartment, which is easily accessible from the outside. The switch settings for the most common comparable conventional lamps are noted on a sticker.

	1	2	3	4	5	6	7	8	Performance	Substitute for
on off	■ ■	■ ■	■ ■	■ ■	■ ■	■ ■	■ ■	■ ■	34 W	2 x HME 125
on off	■ ■	■ ■	■ ■	■ ■	■ ■	■ ■	■ ■	■ ■	46 W	HST 100
on off	■ ■	■ ■	■ ■	■ ■	■ ■	■ ■	■ ■	■ ■	54 W	HME 250
on off	■ ■	■ ■	■ ■	■ ■	■ ■	■ ■	■ ■	■ ■	70 W	HSE 150



TECHNICAL PROPERTIES

Series 7600 FOCO VARIO

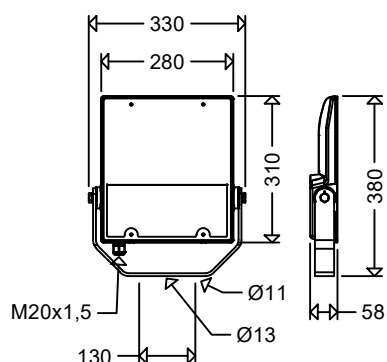

i

All light fittings also available with connected cable (H07RN-F or NYM) in the required length.

	7600 FOCO VARIO	
Recommended mounting height	3 - 6 m	
Wind-exposed surface	0.02 m ² (0° mounting)	0.09 m ² (spotlight)
Luminaire luminous flux (LF 740)	1,370 - 11,170 lm	
Luminaire luminous flux (LF 730)	1,300 - 10,610 lm	
System performance	9 - 70 W	
Luminous efficacy (LF 740)	152 - 177 lm/W	
Luminous efficacy (LF 730)	144 - 168 lm/W	
Optics	B, TB, T, TX, A, AB, ABL	
Light colours	740, 730, 722, 518	
Control functions	LR, LA, CL, DIMD	
Light management	LIMAS Air SYNC, RFL	
Variable luminous flux setting	VARIO	
IP rating	IP66	
Protection class (standard / option)	I / II	
ECG	220 - 240 V, 50 - 60 Hz	
IK rating	10 kV	
LED module	Highpower, Zhaga compliant	
Service life	L90 > 100,000 h	
Energy efficiency class	B	

Options:

High resistance against harmful gases and corrosive atmospheres, seawater-resistant version, backside light shielding, for connection to a central power supply system, special painting in RAL colours

STANDARD TYPES

The standard versions of the series are listed in the table. Customised lumen packages can be programmed at the factory.

Type	Connected load [W]	Luminaire luminous flux [lm]		Luminous efficiency [lm/W]		Weight [kg]
		LF 740	LF 730	LF 740	LF 730	
7600 L50 VARIO	9	1,370	1,300	152	144	3.8
	15	2,590	2,460	173	164	3.8
	18	3,190 ¹⁾	3,030	177	168	3.8
	35	5,660	5,380	162	154	3.8
7600 L100 VARIO	16	2,740	2,600	171	163	3.9
	38	6,740	6,400	177	168	3.9
	54	9,030 ¹⁾	8,580	167	159	3.9
	70	11,170	10,610	160	152	3.9

The luminaires are available with additional optics, light colours, control functions and light management. (see "Technical features")

¹⁾ Factory settings

POLE TOPS

Pole tops for pole braid diameter 76 mm

Pole top for 1 to 4 luminaires are available for pole mounting.

Type	Description	Weight [kg]
MAU 1 76/130 M10	Pole top for single mounting; galvanised steel	2.4
MAU 2 76/130 M10	Pole top for double mounting; galvanised steel	2.7
MAU 3 76/130 M10	Pole top for triple mounting; galvanised steel	2.9
MAU 4 76/130 M10	Pole top for quadruple mounting; galvanised steel	3.1

Single mounting: MAU 1 76/130 M10

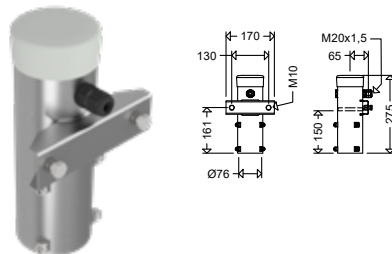

Double mounting: MAU 2 76/130 M10

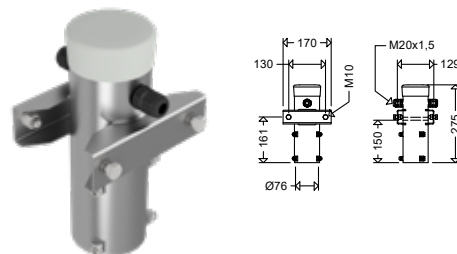

Threefold mounting: MAU 3 76/130 M10

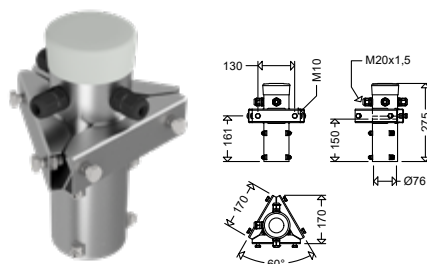

Fourfold mounting: MAU 4 76/130 M10

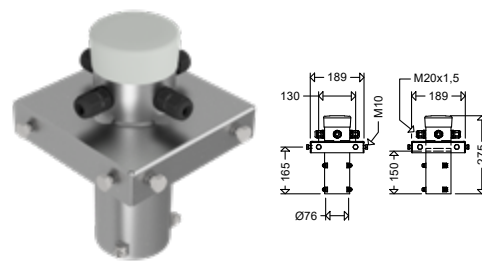



FOCO L / FOCO XL

SERIES 7700 / 7800



Wherever large areas need to be illuminated, e.g. car parks, farmyards, vehicle depots, storage areas, loading areas or construction sites, the spotlights of the FOCO family show their full power.

With their extremely flat design and subtle cooling fin structure, they look modern and

elegant. The luminaires also score highly with their technical features and quality. The direct connection of the LED modules to the robust die-cast aluminium housing results in excellent thermal management and thus makes a decisive contribution to the extremely long service life. Like all SCHUCH

LED outdoor luminaires, they also feature high surge protection and Zhaga-compliant LED modules, ensuring that future LED generation or system changes can be carried out without any problems. A future-proof, long-term investment without risk.



Vorteile

- Excellent thermal management thanks to direct connection of the LED modules to the die-cast aluminium housing
- Homogeneous illumination due to the Multi-Layer-Technology
- Optimal light distribution due to highly efficient optics
- Comfortable maintenance due to removable lower part of the housing, large opening allows easy access to the terminal box and the electrical components
- Integrated pressure equalisation system prevents condensation in the interior
- Eco-friendly, no light emission into the upper half-space, ULOR=0 (Plane Surface Floodlight)
- Versions dimmable to 10 % with luminous fluxes up to 2000 lm and with color temperature up to 3,000 K comply with Dark Sky requirements
- Sustainable, control gear and LED-module replaceable by qualified personnel on-site
- Future proof by using standardized LED-modules (Zhaga) and long-term availability of spare parts
- GreenLine luminaire, outstanding sustainable design

Main applications



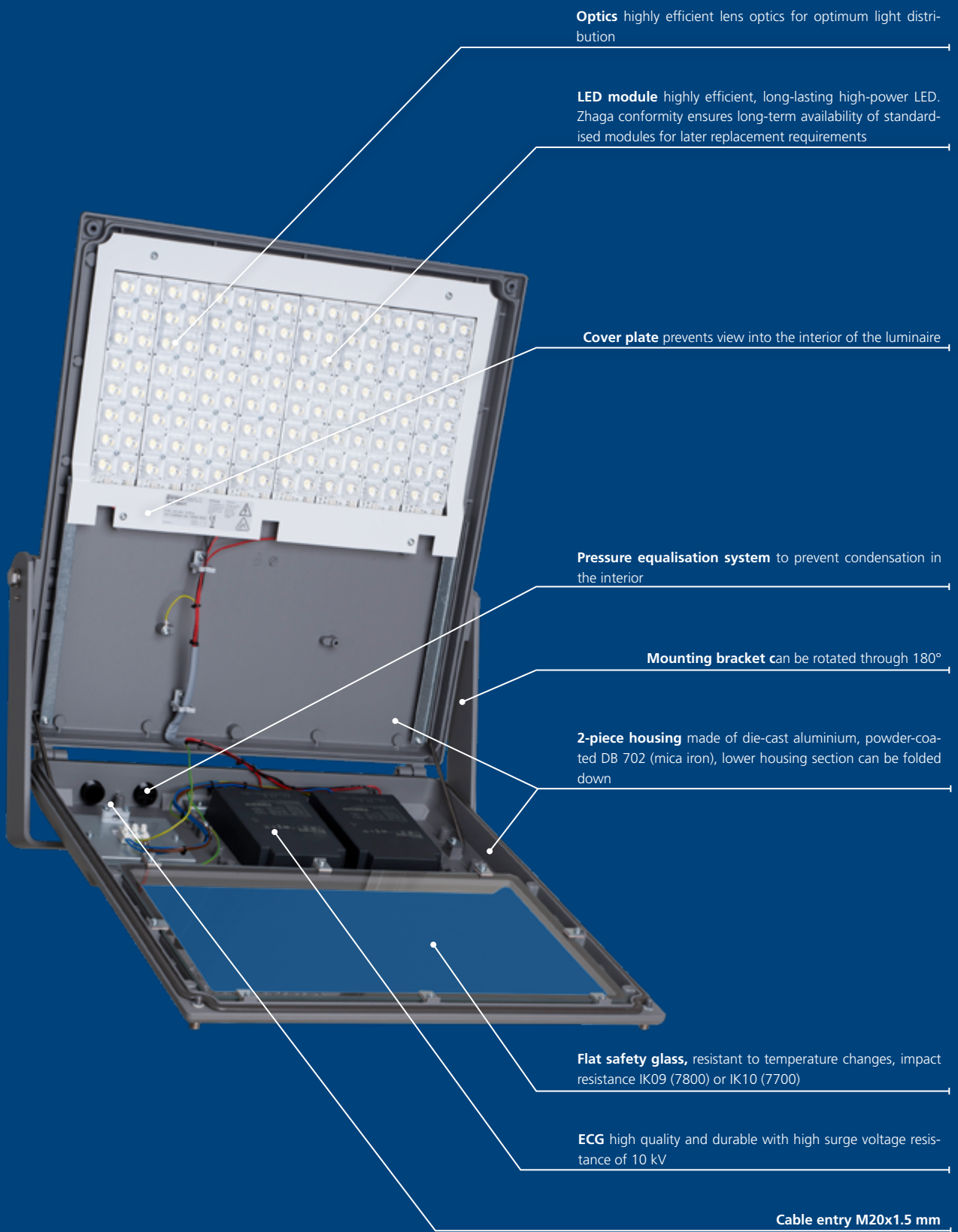

Optics highly efficient lens optics for optimum light distribution

LED module highly efficient, long-lasting high-power LED. Zhaga conformity ensures long-term availability of standardised modules for later replacement requirements

Cover plate prevents view into the interior of the luminaire

Pressure equalisation system to prevent condensation in the interior

Mounting bracket can be rotated through 180°

2-piece housing made of die-cast aluminium, powder-coated DB 702 (mica iron), lower housing section can be folded down

Flat safety glass, resistant to temperature changes, impact resistance IK09 (7800) or IK10 (7700)

ECG high quality and durable with high surge voltage resistance of 10 kV

Cable entry M20x1.5 mm



TECHNICAL PROPERTIES

Series 7700 FOCO L

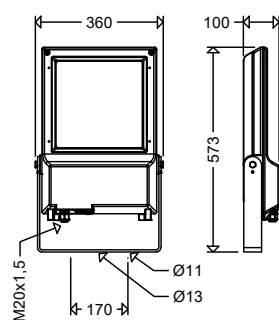

Series 7800 FOCO XL

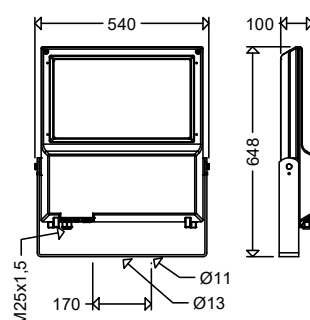

i All light fittings also available with connected cable (H07RN-F or NYM) in the required length.

	7700 FOCO L		7800 FOCO XL	
Recommended mounting height	6 - 10 m		6 - 14 m	
Wind-exposed surface	0.05 m ² (0° mounting)	0.15 m ² (spotlight)	0.05 m ² (0° mounting)	0.27 m ² (spotlight)
Luminaire luminous flux (LF 740)	11,360 - 21,940 lm		22,650 - 43,920 lm	
Luminaire luminous flux (LF 740) VARIO / NFC	2,760 - 21,940 lm		5,550 - 43,920 lm	
Luminaire luminous flux (LF 730)	10,790 - 20,840 lm		21,520 - 41,720 lm	
Luminaire luminous flux (LF 730) VARIO / NFC	2,620 - 20,840 lm		5,270 - 41,720 lm	
Connected load	70 - 140 W		140 - 280 W	
Connected load VARIO / NFC	16 - 140 W		32 - 280 W	
Luminous efficacy (LF 740)	157 - 162 lm/W		157 - 162 lm/W	
Luminous efficacy (LF 740) VARIO / NFC	157 - 179 lm/W		157 - 173 lm/W	
Luminous efficacy (LF 730)	149 - 154 lm/W		149 - 154 lm/W	
Luminous efficacy (LF 730) VARIO / NFC	149 - 171 lm/W		149 - 164 lm/W	
Optics	B, TB, T, TX, A, AB, ABL			
Light colours	740, 730, 722, 518			
Control functions	LR, LA, CL, DIMD, EcoTune			
Light management	LIMAS Air SYNC, RFL			
Variable luminous flux setting	VARIO / NFC			
IP rating	IP 66			
Protection class	I			
ECG	220 - 240 V, 50 - 60 Hz			
Surge voltage resistance	10 kV			
LED module	Zhaga compliant			
Service life	L90 > 100,000 h			
Energy efficiency class	B			
IK rating	IK10		IK09	
ENEC / VDE mark	no		yes	

Options:

High resistance against harmful gases and corrosive atmospheres, seawater-resistant version, for floodgates, for connection to a central power supply system, special painting in RAL colours

STANDARD TYPES

The standard versions of the series are listed in the table. Customised lumen packages can be programmed at the factory.

Type	Connected load [W]	Luminaire luminous flux [lm]		Luminous efficiency [lm/W]		Weight [kg]
		LF 740	LF 730	LF 740	LF 730	
7700 3203	70	11,360	10,790	162	154	9.5
7700 4803	106	16,790	15,950	158	150	9.7
7700 6403	140	21,940	20,840	157	149	9.7
7700 L100 VARIO / NFC	16	2,760	2,620	173	164	9.5
	38	6,820	6,480	179	171	9.5
	54	9,160	8,700	170	161	9.5
7700 L150 VARIO / NFC	70	11,360	10,790	162	154	9.5
	24	4,120	3,910	172	163	9.7
	45	7,770	7,380	173	164	9.7
	82	13,590	12,910	166	157	9.7
7700 L210 VARIO / NFC	106	16,790 ¹⁾	15,950	158	150	9.7
	32	5,400	5,130	169	160	9.7
	79	13,260	12,600	168	159	9.7
	99	16,300	15,490	165	156	9.7
	140	21,940 ¹⁾	20,840	157	149	9.7

Type	Connected load [W]	Luminaire luminous flux [lm]		Luminous efficiency [lm/W]		Weight [kg]
		LF 740	LF 730	LF 740	LF 730	
7800 6403	140	22,650	21,520	162	154	15.9
7800 12803 ²⁾	280	43,920	41,720	157	149	17.0
7800 L210 VARIO / NFC	32	5,550	5,270	173	165	15.9
	79	13,660	12,980	173	164	15.9
	99	16,800	15,960	170	161	15.9
7800 L420 VARIO / NFC	140	22,650 ¹⁾	21,520	162	154	15.9
	64	10,860	10,320	170	161	17.0
	158	26,650	25,320	169	160	17.0
	198	32,720	31,080	165	157	17.0
	280	43,920 ¹⁾	41,720	157	149	17.0

The luminaires are available with additional optics, light colours, control functions and light management. (see "Technical properties")

¹⁾ Factory settings

MAST TOPS

Mast attachment for mast spigot diameter 76 mm

Type	Description of the
MAU 1 76/170 M10	Pole top for single mounting; galvanised steel
MAU 2 76/170 M10	Pole top for double mounting; galvanised steel

Single mounting: MAU 1 76/170 M10

Double mounting: MAU 2 76/170 M10

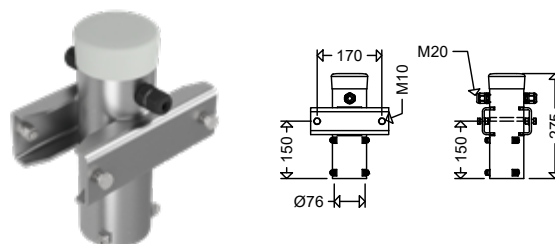
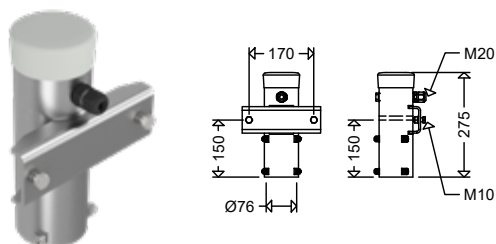



AREALO 2

SERIES 7950



Durable, efficient, environmentally friendly and absolutely powerful - the AREALO 2 large-area spotlight sets new standards and impresses in particular with its low overall weight and flat design. Its corrosion-resistant die-cast aluminium housing ensures maximum durability, while the optimised thermal management guarantees a long

service life. In terms of ease of installation, it impresses with its low weight, the resulting significantly reduced load on the mast and the externally accessible connection compartment, which enables quick and convenient electrical connection. Sustainability and future-proofing are also firmly anchored in the concept: a ULOR value of 0, repla-

ceable components, Zhaga-compliant LED modules and long-term availability of spare parts are a matter of course.

The AREALO 2 large-area spotlight meets all of the strict GreenLine sustainability criteria and is therefore one of the most outstanding sustainable products in our range.

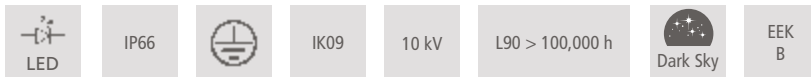

ADVANTAGES

- Durable, corrosion-resistant die-cast aluminium housing
- Low total weight, low mast load
- Quick electrical connection due to outlying electrical connection box
- Excellent thermal management, long service life
- Homogeneous illumination due to the Multi-Layer-Technology
- Eco-friendly, no light emission into the upper half-space, ULOR = 0
- Versions dimmable to 10 % with luminous fluxes up to 2000 lm and with color temperature up to 3,000 K comply with Dark Sky requirements
- Sustainable, control gear and LED-module replaceable by qualified personnel on-site
- Future proof by using standardized LED-modules (Zhaga) and long-term availability of spare parts
- GreenLine luminaire, outstanding sustainable design

Main applications

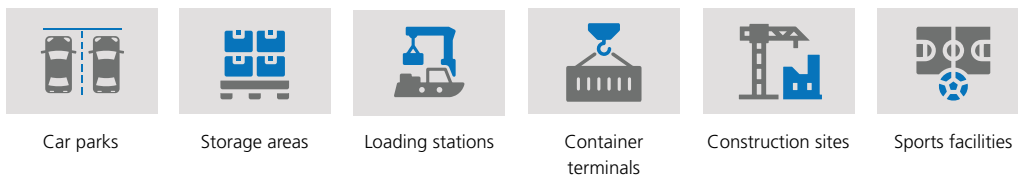

Robust die-cast aluminium housing with excellent thermal management, powder-coated DB 702 (mica iron)

High-quality, durable ECG with additional surge protection up to 10kV. With the OV version (without ballast), the separate ECG unit can be installed in the pole. This eliminates the need for a ladder when replacing the ECG.

Highly efficient lens optics for optimum light beam

LED module highly efficient, long-lasting high-power LED. Zhaga conformity ensures long-term availability of standardised modules for later replacement requirements

Flat, temperature-resistant safety glass with high impact resistance IK09



Mounting bracket can be rotated 180° in 5° increments

Pressure equalisation system to prevent condensation in the interior

Quick electrical connection due to outlying electrical connection box

OPTICS

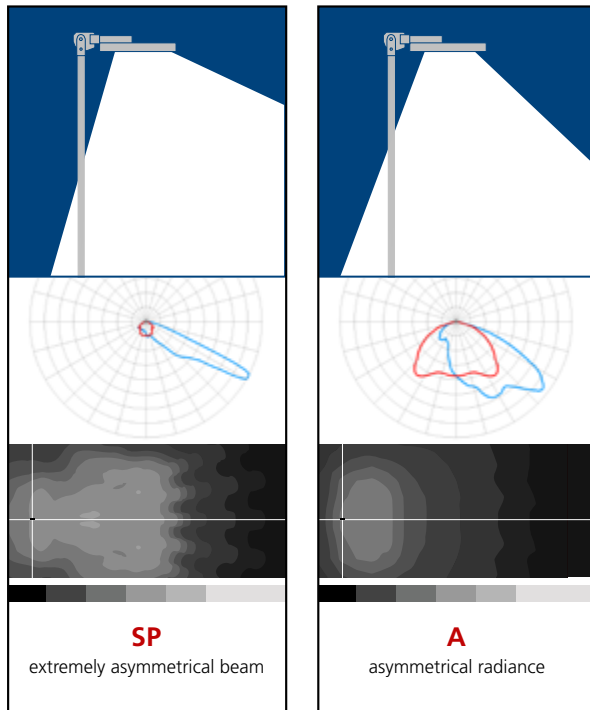

Further optics

B

wide beam

TB

narrow beam

T

narrow beam

TX

extremely narrow beam

(see page 112)

CROSSBAR MOUNTING OPTION

Spotlights for large areas must be mounted on masts at great heights. This cannot be done without a ladder. That is why installation should be as simple and easy as possible. The AREALO 2 is exemplary in this respect.

Thanks to its low weight and the resulting significantly reduced mast load, there is nothing to prevent the installation of up to 5 luminaires per mast on a crossbar.

The luminaires are precisely aligned using the mounting bracket, which can be swivelled in 5° increments up to 180°. In addition, the luminaires can be flexibly swivelled up to 50° to the side at the four outer mounting points of the crossbar, as shown in the photo on the right. The desired angle can be set quickly and easily with a practical alignment aid (template) that is included with each crossbar.

The distribution box required for the electrical connection is also mounted on the crossbar, so only one cable is needed in/on the pole.

Various crossbars are available to enable different combination options.



TECHNICAL PROPERTIES

Series 7950 AREALO 2

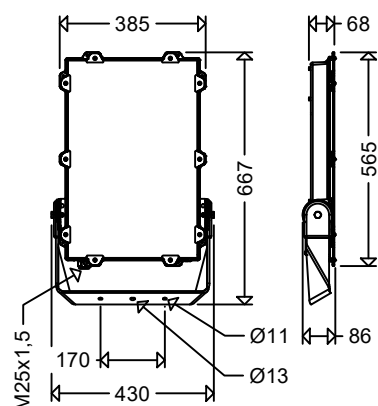

i

All light fittings also available with connected cable (H07RN-F or NYM) in the required length.

	7950 AREALO 2	
Recommended mounting height	from 12 m	
Wind-exposed surface	0.05 m ² (0° mounting)	0.2 m ² (spotlight)
Luminaire luminous flux (LF 740)	26,500 – 66,500 lm	
Luminaire luminous flux (LF 730)	25,200 – 63,200 lm	
Connected load	144 – 432 W	
Luminous efficiency (LF 740)	154 – 184 lm/W	
Luminous efficiency (LF 730)	146 – 175 lm/W	
Optics	SP, A	
Light colour	740, 730, 722, 518	
Control functions	LR, LA, CL, DIMD	
Lichtmanagement	LIMAS Line, LIMAS Air CASA, RFL	
IP rating	IP66	
Protection class	I	
ECG	220 – 240 V, 50 – 60 Hz	
IK rating	10 kV	
LED module	Highpower, Zhaga compliant	
Service life	L90 > 100,000 h	
Energy efficiency class	B	

Optionen:

seawater-resistant version, vibration-resistant design und bird deterrence, version with separate ECG for pole mounting, special painting in RAL colours

STANDARD TYPES

The standard versions of the series are listed in the table. Customised lumen packages can be programmed at the factory.

Type	Connected load [W]	Luminaire luminous flux [lm]		Luminous efficiency [lm/W]		Weight [kg]
		LF 740	LF 730	LF 740	LF 730	
7950 14401SP OP	144	26,500	25,200	184	175	10.7
7950 14402SP OP	209	36,800	35,000	176	167	10.7
7950 14403SP OP	298	49,300	46,800	165	157	11.0
7950 14404SP OP	432	66,500	63,200	154	146	11.0
7950 14401SP DIMD OP	144	26,500	25,200	184	175	10.7
7950 14402SP DIMD OP	209	36,800	35,000	176	167	10.7
7950 14403SP DIMD OP	298	49,300	46,800	165	157	11.0
7950 14404SP DIMD OP	432	66,500	63,200	154	146	11.0

Luminaire without ballasts, separate ECG unit 7950 required

Type	Connected load [W]	Luminaire luminous flux [lm]		Luminous efficiency [lm/W]		Weight [kg]
		LF 740	LF 730	LF 740	LF 730	
7950 14401SP OV	144	26,500	25,200	184	175	10.3
7950 14402SP OV	209	36,800	35,000	176	167	10.3
7950 14403SP OV	298	49,300	46,800	165	157	10.3
7950 14404SP OV	432	66,500	63,200	154	146	10.3

The luminaires are available with additional optics, light colours, control functions and light management. (see "Technical features")

EVG units for internal pole mounting

Type	Description	EVG
EVG 7950 1 14401 OV	ECG unit for one luminaire 7950 14401 OV	Typ 1
EVG 7950 2 14401 OV	ECG unit for two luminaires 7950 14401 OV	Typ 1
EVG 7950 3 14401 OV	ECG unit for three luminaires 7950 14401 OV	Typ 1
EVG 7950 1 14402 OV	ECG unit for one luminaire 7950 14402 OV	Typ 1
EVG 7950 2 14402 OV	ECG unit for two luminaires 7950 14402 OV	Typ 1
EVG 7950 3 14402 OV	ECG unit for three luminaires 7950 14402 OV	Typ 2
EVG 7950 1 14403 OV	ECG unit for one luminaire 7950 14403 OV	Typ 1
EVG 7950 2 14403 OV	ECG unit for two luminaires 7950 14403 OV	Typ 1
EVG 7950 3 14403 OV	ECG unit for three luminaires 7950 14403 OV	Typ 2
EVG 7950 1 14404 OV	ECG unit for one luminaire 7950 14404 OV	Typ 1
EVG 7950 2 14404 OV	ECG unit for two luminaires 7950 14404 OV	Typ 2
EVG 7950 3 14404 OV	ECG unit for three luminaires 7950 14404 OV	Typ 4
EVG 7950 4 14404 OV	ECG unit for four luminaires 7950 14404 OV	2x Typ 2

Typ 1 & 2

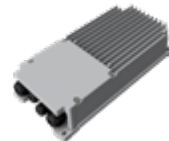
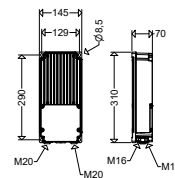

Typ 4

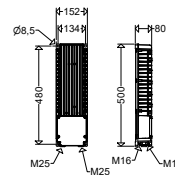

Distribution box

Type	Description
VBOX 5 TR	Distribution box for combining the connection cables of several AREALO 2 units. 6 loose cable glands, support plate and screws for direct attachment to the crossbar included in the scope of delivery.
VBOX RFL TR	Distribution box with RFL socket for crossbar mounting.

Crossbar

For mast mounting for Ø 108 mm or Ø 76 mm

Type	Description	D
TR 1200/108/170/5 M10/12	Crossbar with 5 fastening options for floodlights on a pole	108
TR 900/108/170/4 M10/12	Crossbar with 4 fastening options for floodlights on a pole	108
TR 1200/76/170/5 M10/12	Crossbar with 5 fastening options for floodlights on a pole	76
TR 900/76/170/4 M10/12	Crossbar with 4 fastening options for floodlights on a pole	76

TR 1200/108/170/5 M10/12

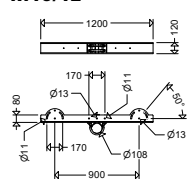

TR 900/108/170/4 M10/12

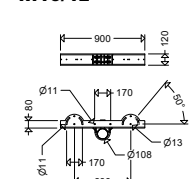



SPORTS FACILITY LIGHTING WITH AREALO 2

Whether small-field facilities, sports fields or training grounds for football, hockey, tennis, etc., the powerful, energy-efficient and durable floodlights of the AREALO 2 series offer you a wide range of possibilities. Our goal is to achieve the best possible results for your sports facility in terms of illuminance, uniformity and glare control, taking into

account the requirements of DIN 12193. Among many other advantages, the extremely long service life of the AREALO 2, at least 100,000 hours, is particularly noteworthy. With an average of 300-500 operating hours per year, this is an investment for generations, maintenance-free and without regular

lamp replacement, as is the case with conventional systems. The use of the LIMAS Air CASA light management system also allows maximum savings in energy costs and CO₂ emissions.

INTELLIGENT LIGHT CONTROL

Simply switching the floodlights of a sports facility on and off is neither efficient nor cost-saving and environmentally friendly. When converting to LED technology, the question of intelligent lighting control there-

fore arises. If one then takes into account the subsidies from the federal government within the framework of the municipal guidelines as well as the state sports associations and possibly the respective federal

state, which can currently amount to up to 80 % cumulatively at peak times, the decision should not be difficult.

Dimming

The introduction to light control

The simplest solution is to dim the floodlights via DALI. Since the maximum illuminance is usually only required for matches and competitions, energy can be saved to a considerable extent by continuously dim-

ming or switching on preset lighting levels during training. All that is required for this are AREALO 2 luminaires in DIMD design and DALI wiring to the masts.



SMART LIGHT CONTROL WITH LIMAS AIR CASA

With the LIMAS Air CASA light management system, you can conveniently control your floodlight system radio-based, without additional wiring, while saving the maximum amount of energy costs. The system is configured and controlled using a free app (Android or iOS) via smartphone or tablet. No internet connection or gateway is required for this.

The light intensity of each individual luminaire can be controlled separately. This requires RFL luminaires that are controlled by a light management controller (RFL LACA FM DS). To control an entire mast unit (crossbar mounting), all you need is a distribution box (VBOX RFL TR), which is also mounted on the crossbar and equipped with the LIMAS Air CASA Controller. This not only prevents vandalism, but also ensures optimum reach for the the control signal.

In conjunction with push buttons, the pre-programmed scenes can be called up easily and conveniently, for example, match and competition mode, training, half-field lighting or goalkeeper training, etc.

Please contact us. We will be happy to show you the possibilities offered by LIMAS Air CASA and support you in the planning, project management and configuration of your system.



7950 ...SP OP RFLSO, AREALO 2 with RFL socket and LIMAS Air CASA Controller







7950 ... SP OP, AREALO 2 plus separate distribution box with RFL socket and LIMAS Air CASA Controller



Versions

Type	Connected load [W]	Luminous flux [lm]		Luminous efficacy [lm/W]		Weight [kg]
		LF 740	LF 730	LF 740	LF 730	
7950 14404SP DIMD OP	432	66,500	63.200	154	146	11.0
7950 14404SP OP RFLSO	432	66,500	63.200	154	146	11.0

LIMAS Air CASA System components

RFL LACA FM DS	CASAMBI® radio module with light sensor for RFL sockets	
LACA TASTIF4 UP	CASAMBI® push-button interface for connecting up to 4 volt-free push-button inputs. Designed for installation in a flush-mounted wall box	
LACA TAST4 AP	Battery-free, 4-button CASAMBI® radio switch. Actuating the switch generates the energy required to power the switch electronics	
LACA SENSBOX	External unit with integrated RFLS socket for connecting a radio module (can be combined with LIMAS Air CASA)	
VBOX RFL TR	Distribution box with RFL socket for crossbar mounting	



PLANNING EXAMPLES FOR SPORTS FIELD LIGHTING

The basis for planning is the DIN EN 12193 regulation. It defines clear standards for illuminance, uniformity, glare limitation and color rendering for different lighting classes.

Lighting classes

Class I	High-performance competitions, international and national competitions with high visual requirements, high-performance training
Class II	Intermediate level competitions, regional competitions with medium visual requirements, performance training
Class III	Simple competitions, local competitions, school sports, general leisure sports, general training

Requirements

Lighting class	average horizontal illuminance (Em)	Uniformity (Uo)
I	≥ 500 lx	≥ 0.7
II	≥ 200 lx	≥ 0.6
III	≥ 75 lx	≥ 0.5

Example 1 Soccer field, lighting class III, 6-pole system

Facility data

Field size according to FIFA	105 x 68 m
Light spot height	16 m
Distance between mast & playing field	3 m
Maintenance factor	0.90

Lighting requirements

Mean horizontal illuminance	$\geq 75 \text{ lx}$
Uniformity	≥ 0.5

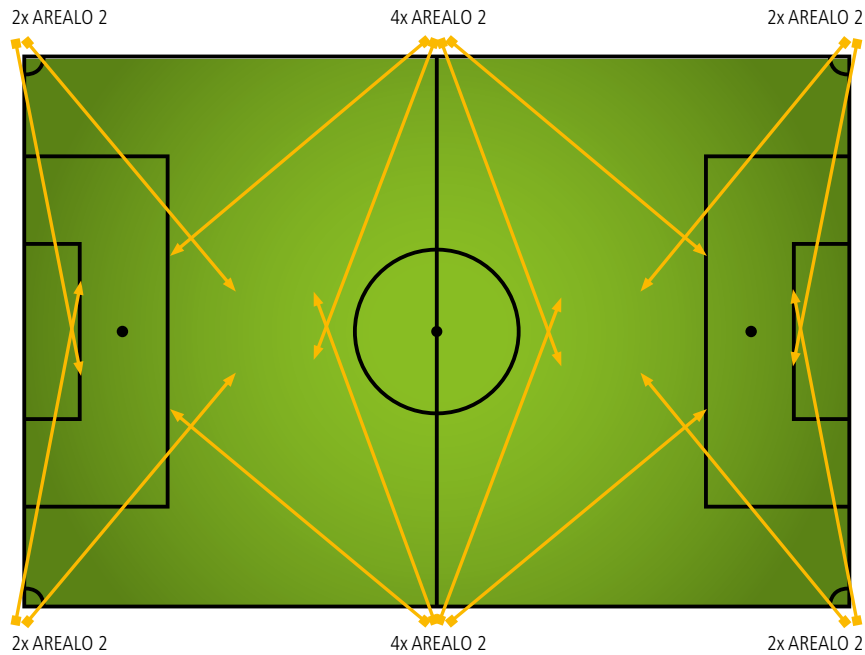

Lichtfarbe 730

Standard solution:

16 x AREALO 2 7950 14404SP 730 OP

Solution with LIMAS Air

16 x 7950 14404SP OP RFLSO
16 x RFL LACA FM DS

Ergebnis:

Mean horizontal illuminance: **Em = 78 lx**
Uniformity: **Uo = 0.62**
ULOR: **0 %**
Output: **6.9 kW**

Lichtfarbe 740

Standard solution:

16 x AREALO 2 7950 14404SP OP

Solution with LIMAS Air

16 x 7950 14404SP OP RFLSO
16 x RFL LACA FM DS

Ergebnis:

Mean horizontal illuminance: **Em = 82 lx**
Uniformity: **Uo = 0.62**
ULOR: **0 %**
Output: **6.9 kW**

Example 2 Soccer field, lighting class III, 4-pole system

Investment data

Field size according to FIFA	105 x 68 m
Light spot height	16 m
Distance between mast & playing field	3 m
Maintenance factor	0.90

Lighting requirements

Mean horizontal illuminance	$\geq 75 \text{ lx}$
Uniformity	≥ 0.5

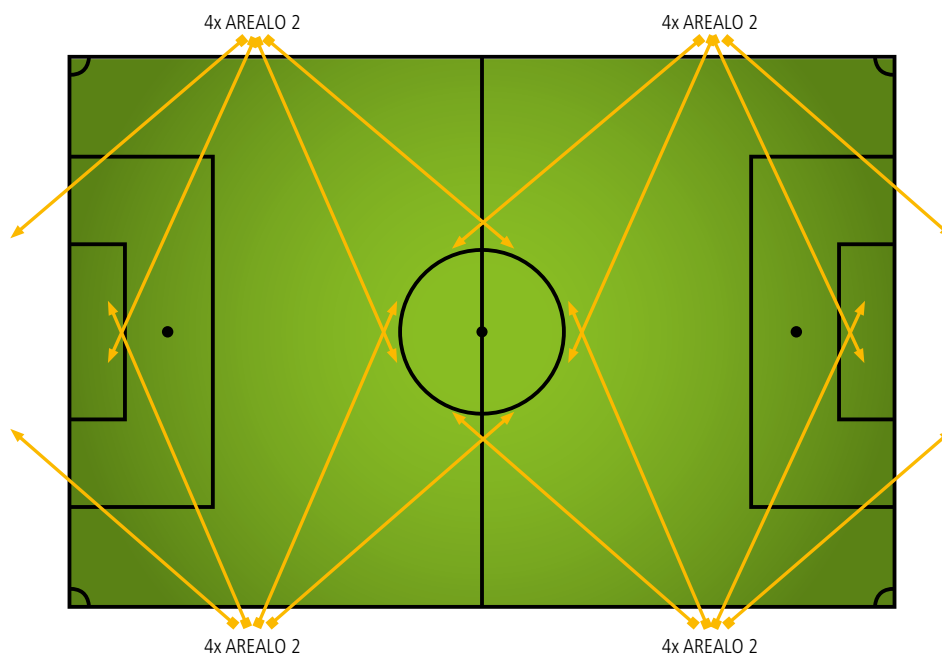

730

Lichtfarbe 730

Standard solution:

16 x AREALO 2 7950 14404SP 730 OP

Solution with LIMAS Air:

16 x 7950 14404SP OP RFLSO
16 x RFL LACA FM DS

Ergebnis:

Mean horizontal illuminance: **Em = 78 lx**
Uniformity: **Uo = 0.55**
ULOR: **0 %**
Output: **6.9 kW**

740

Lichtfarbe 740

Standard solution:

16 x AREALO 2 7950 14404SP OP

Solution with LIMAS Air

16 x 7950 14404SP OP RFLSO
16 x RFL LACA FM DS

Ergebnis:

Mean horizontal illuminance: **Em = 83 lx**
Uniformity: **Uo = 0.55**
ULOR: **0 %**
Output: **6.9 kW**

Example 3 football field, lighting class II, 8-pole system

Facility data

Field size according to FIFA	105 x 68 m
Light spot height	18 m
Distance between mast & playing field	3 m
Maintenance factor	0.90

Lighting requirements

Mean horizontal illuminance	$\geq 200 \text{ lx}$
Uniformity	≥ 0.6

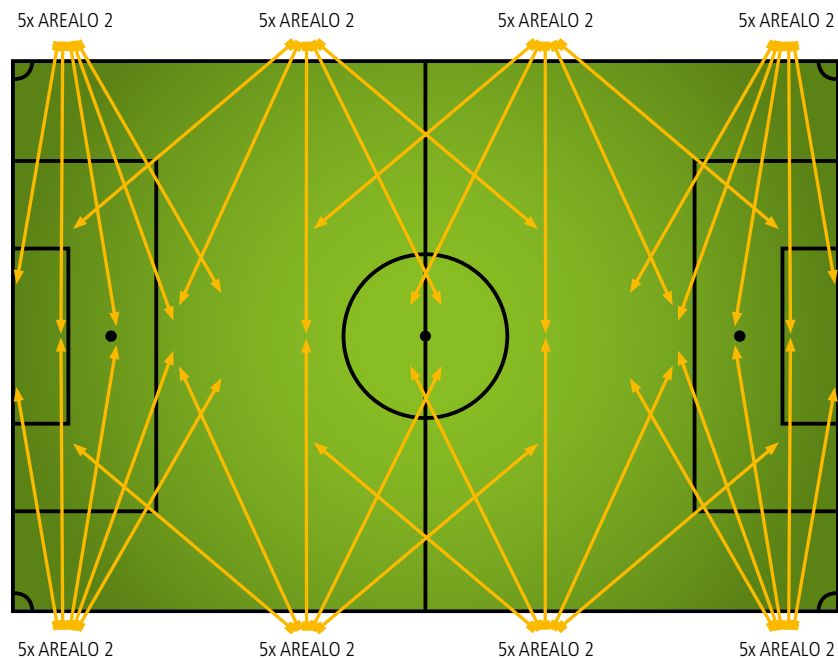

730

Lichtfarbe 730

Standard solution:

40 x AREALO 2 7950 14404SP 730 OP

Solution with LIMAS Air:

40 x AREALO 2 7950 14404SP OP RFLSO
40 x RFL LACA FM DS

Result:

Mean horizontal illuminance: **Em = 206 lx**
Uniformity: **Uo = 0.73**
ULOR: **0 %**
Output: **17.3 kW**

740

Lichtfarbe 740

Standard solution:

40x AREALO 2 7950 14404SP OP

Solution with LIMAS Air:

40 x AREALO 2 7950 14404SP OP RFLSO
40 x RFL LACA FM DS

Result:

Mean horizontal illuminance: **Em = 217 lx**
Uniformity: **Uo = 0.73**
ULOR: **0 %**
Output: **17.3 kW**

**With passion
for excellent lighting - since 1895!**



Adolf Schuch GmbH
Lichttechnische Spezialfabrik

Mainzer Straße 172 • 67547 Worms

P.O. Box 21 45 • 67511 Worms

Phone: +49 6241 4091-0

info@schuch.de • www.schuch.de